

OUTLINE 3-PHASE INDUCTION MOTOR

TOTALLY ENCLOSED
FAN COOLED
SQUIRREL CAGE ROTOR
ANTI-FRICTION BEARING

PROJECT NO:
CUSTOMER:
PO. NO:
ORDER NO:

OUTPUT	POLE	SYN. SPEED	VOLT.	FREQ	INSUL.	TIME RATING	MODEL	FRAME NO.
		RPM.	V.	HZ	F	CONT.	TIK-FCKW	N315XM

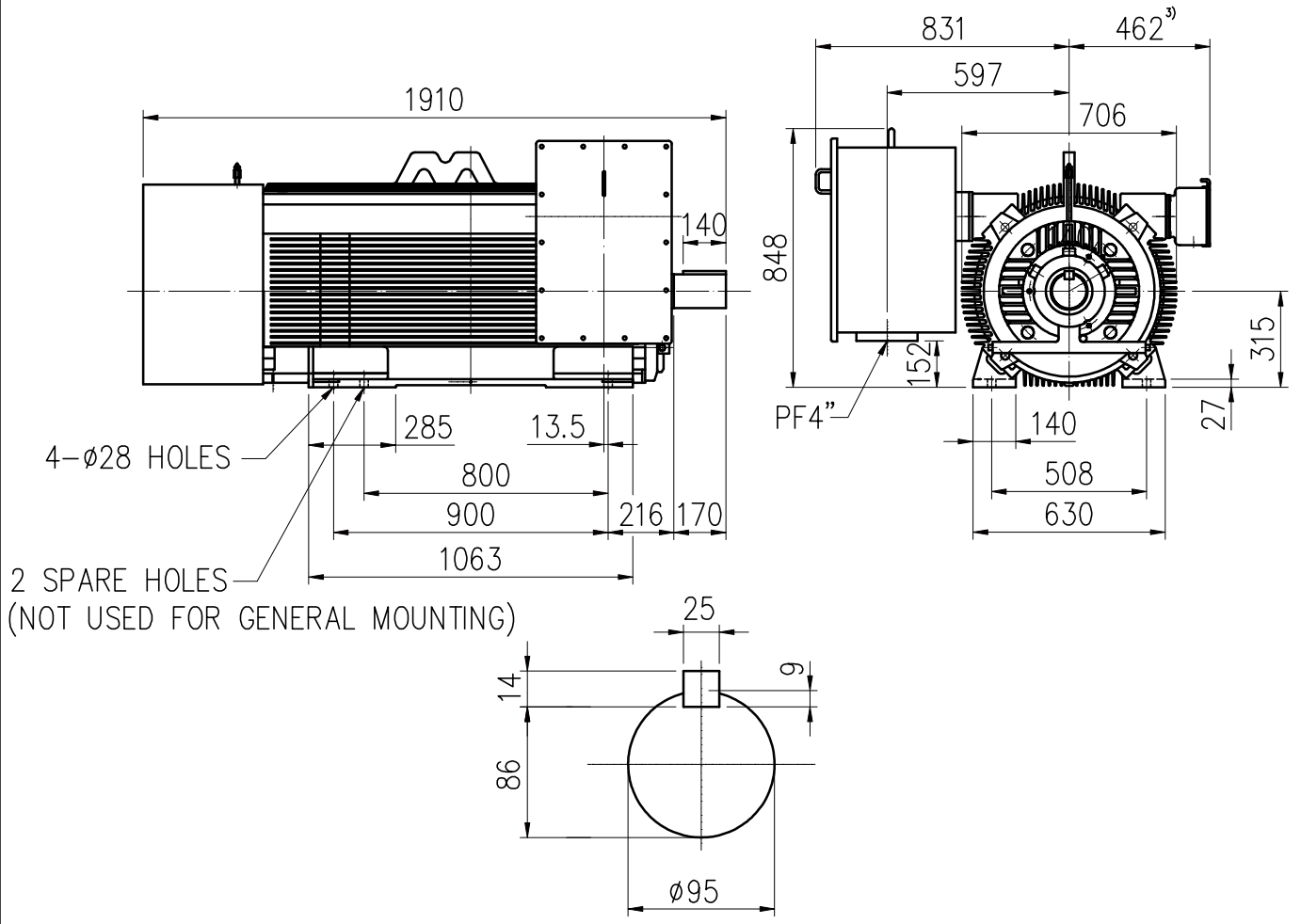

- Note:
- 1) Tolerance of shaft end diameter : m6
 - 2) Tolerance of shaft center height : +0 , -1.0
 - 3) Auxiliary terminal box is optional and dependent on specified accessories.
 - 4) For direct coupling.
 - 5) Approximate weight = 2300 kg
 - 6) Drive end bearing: 6222
Opposite drive end bearing: 6222
 - 7) Direction of rotation : C.W (viewed from non-drive end).
 - 8) Total length will be extended 300 mm to meet 85dBA for 4 pole motors.

Preliminary Drawing for Reference Only



BASIC DWG NO: AL-FB-5599

CERTIFIED BY:		DATE:
DESIGNED	C.Y.WEN	DIMENSIONS IN mm
CHECKED	T.F.CHENG	3RD ANGLE PROJECTION
APPROVED	T.F.CHENG	DATE: NOV.30.2009