

OUTLINE 3-PHASE INDUCTION MOTOR

TOTALLY ENCLOSED
FAN COOLED
SQUIRREL CAGE ROTOR
ANTI-FRICTION BEARING

PROJECT NO:

CUSTOMER:

PO. NO:

ORDER NO:

OUTPUT	POLE	SYN. SPEED	VOLT.	FREQ	INSUL.	TIME RATING	MODEL	FRAME NO.
		RPM.	V.	HZ	F	CONT.	TIK-FCKW	N355LS

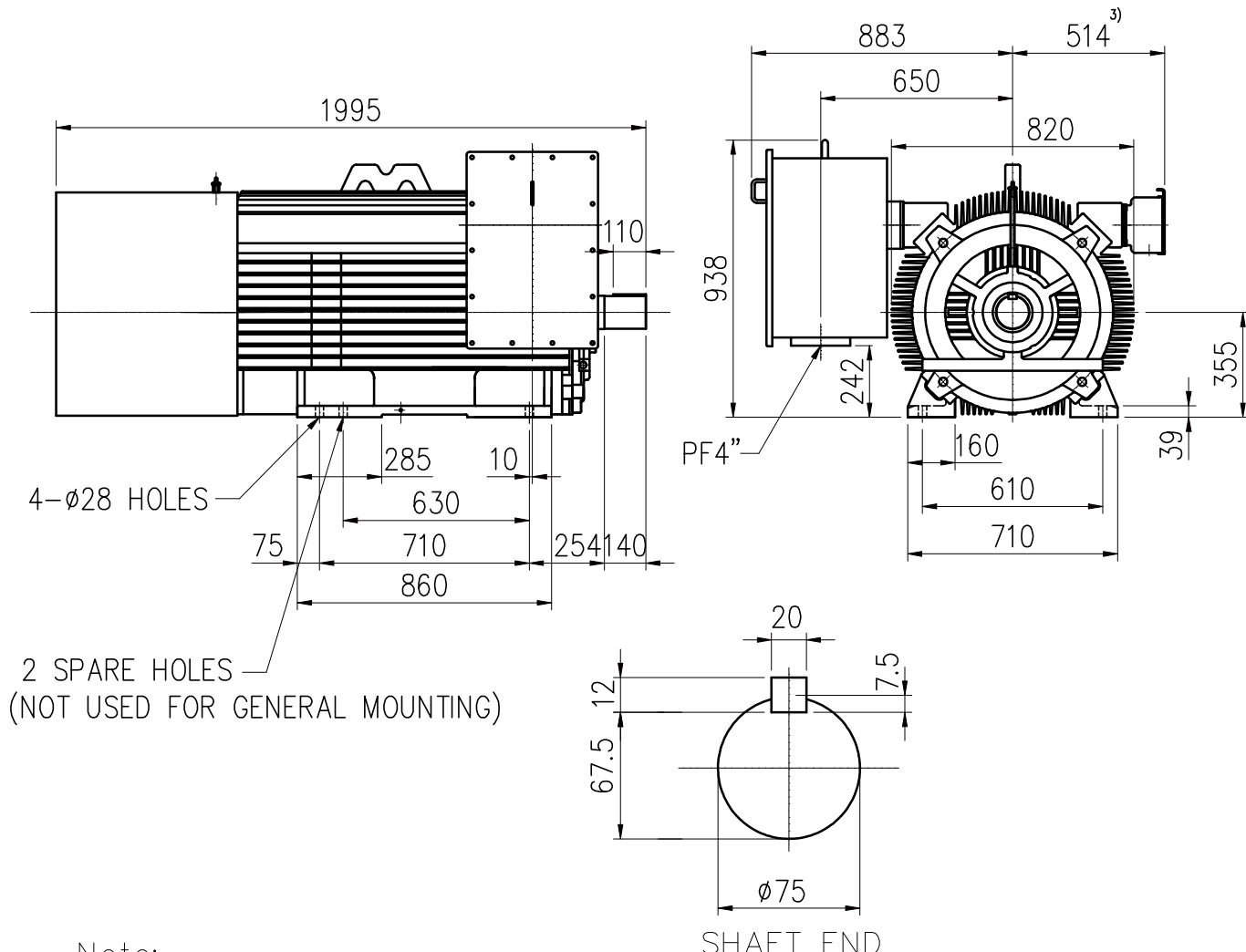

2 SPARE HOLES
(NOT USED FOR GENERAL MOUNTING)

SHAFT END

Note:

- 1) Tolerance of shaft end diameter : m6
- 2) Tolerance of shaft center height : +0 , -1.0
- 3) Auxiliary terminal box is optional and dependent on specified accessories.
- 4) For direct coupling.
- 5) Approximate weight = 2450 kg
- 6) Drive end bearing: 6218C3
Opposite drive end bearing: 6218C3
- 7) Direction of rotation : C.W (viewed from non-drive end)

Preliminary Drawing for Reference Only



BASIC DWG NO: AL-FB-5602

CERTIFIED BY:		DATE:
DESIGNED	C.Y.WEN	DIMENSIONS IN mm
CHECKED	T.F.CHENG	3RD ANGLE PROJECTION
APPROVED	T.F.CHENG	DATE: NOV.30.2009