

OUTLINE 3-PHASE INDUCTION MOTOR

TOTALLY ENCLOSED
FAN COOLED
SQUIRREL CAGE ROTOR
ANTI-FRICTION BEARING

PROJECT NO:
CUSTOMER:
PO. NO:
ORDER NO:

OUTPUT	POLE	SYN. SPEED RPM	VOLT. V	FREQ HZ	INSUL. F	TIME RATING CONT.	MODEL TIK-FCKW	FRAME NO. N400LL
--------	------	-------------------	------------	------------	-------------	----------------------	-------------------	---------------------

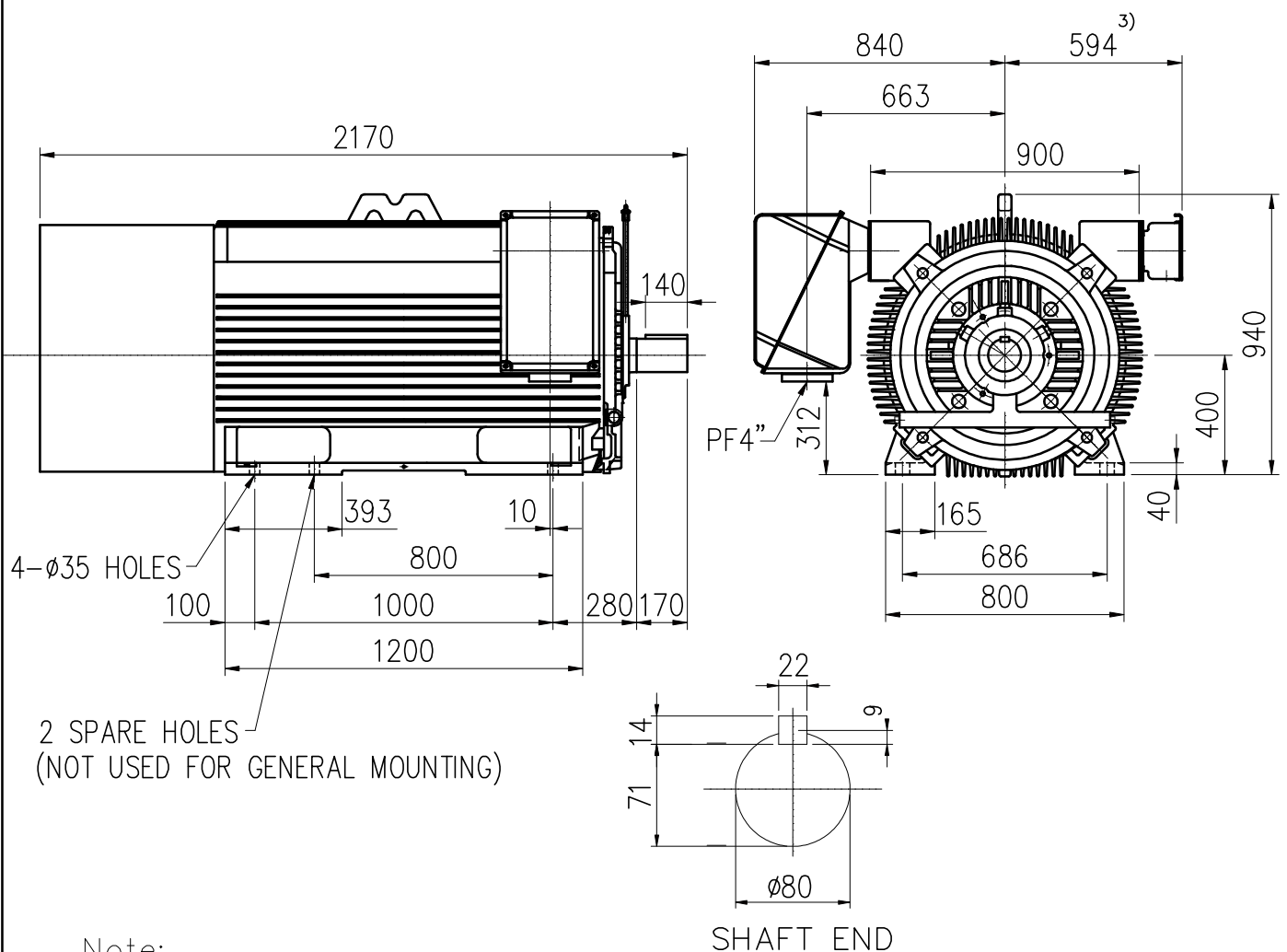

Note:

- 1) Tolerance of shaft end diameter D: m6
- 2) Tolerance of shaft center height H: +0 , -1.0
- 3) Auxiliary terminal box is optional and dependent on specified accessories.
- 4) For direct coupling
- 5) Approximate weight = 4200 kg
- 6) Drive end bearing: 6218C3
Opposite drive end bearing: 6218C3
- 7) Direction of rotation : C.W (viewed from non-drive end)

Preliminary Drawing for Reference Only



BASIC DWG NO: AL-FB-5608

CERTIFIED BY:		DATE:
DESIGNED	C.Y.WEN	DIMENSIONS IN mm
CHECKED	T.F.CHENG	3RD ANGLE PROJECTION
APPROVED	T.F.CHENG	DATE: NOV.30.2009