

# OUTLINE 3-PHASE INDUCTION MOTOR (TS21F II Series)

**TOTALLY ENCLOSED  
FAN COOLED  
SQUIRREL CAGE ROTOR  
SLEEVE BEARING**

**PROJECT NO:**

**CUSTOMER:**

**PO. NO:**

**ORDER NO:**

OUTPUT	POLE	SYN. SPEED	VOLT.	FREQ	INSUL.	TIME RATING	MODEL	FRAME NO.
		RPM	V	HZ	F	CONT.	TIK-FCKN	N560LL

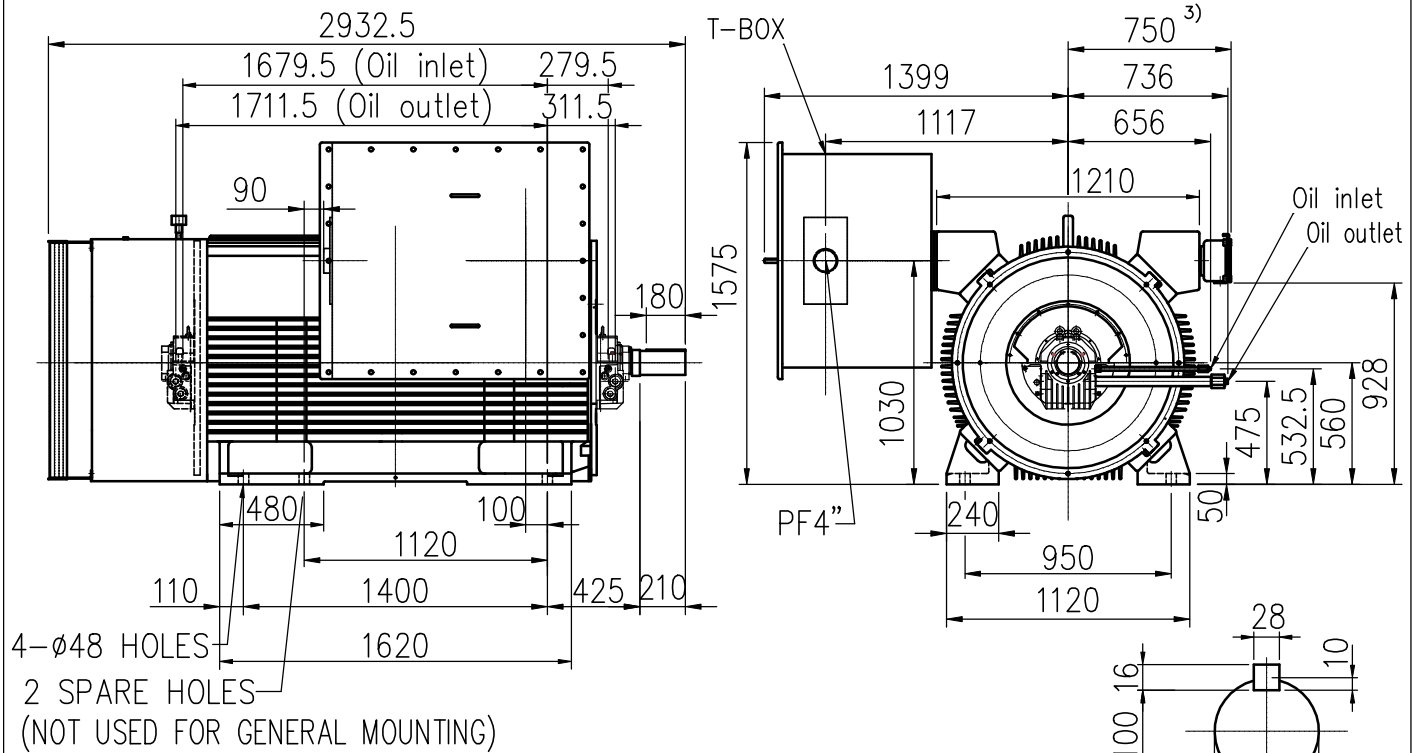

Note:

- 1) Tolerance of shaft end diameter D: m6
- 2) Tolerance of shaft center height H: +0 , -1.0
- 3) Auxiliary terminal box is optional and dependent on specified accessories.
- 4) For direct coupling.
- 5) Approximate weight of maximum rated power= 8600 kg
- 6) Drive end bearing: 09-100

Opposite drive end bearing: 09-100  
Sleeve bearing self lubrication with oil ring.  
Drive end and Non-drive end : Turbine oil ISO VG32  
Lubrication: (a) Quantity of Req: 2X4 L/min  
(b) Oil pressure: 1.0kg/cm  
(c) Oil inlet temp: 40°C (MAX)

Limits of end play 6.5 mm (at one side)  
Allowance of total end play 13mm

7) Rotation:  C.W  Viewed From Non-Drive End.

SHAFT END

Preliminary Only

**TATUNG**  
BASIC DWG NO: FB-5932

<b>CERTIFIED BY:</b>		<b>DATE:</b>
DESIGNED	Y.L.HUANG	DIMENSIONS IN mm
CHECKED	W.C.HUANG	3RD ANGLE PROJECTION
APPROVED	W.C.HUANG	DATE: