

OUTLINE
3-PHASE
INDUCTION MOTOR

TOTALLY ENCLOSED FAN
COOLED, SQUIRREL CAGE
ROTOR
PREMIUM EFFICIENCY
IE3 SERIES

FILE NO:
CUSTOMER:
PO. NO:
ORDER NO:

OUTPUT	POLE	SYN. SPEED	VOLT.	FREQ	TIME RATING	MODEL	FRAME NO.
	2				S1	FHFC	225S

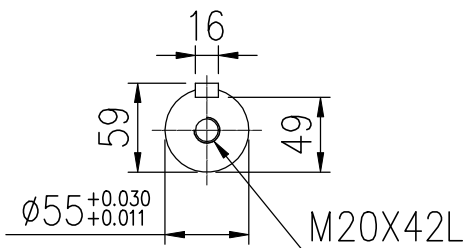
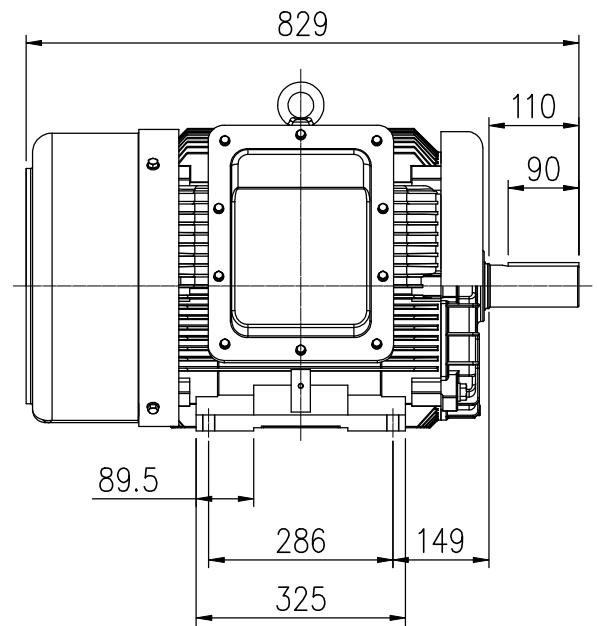
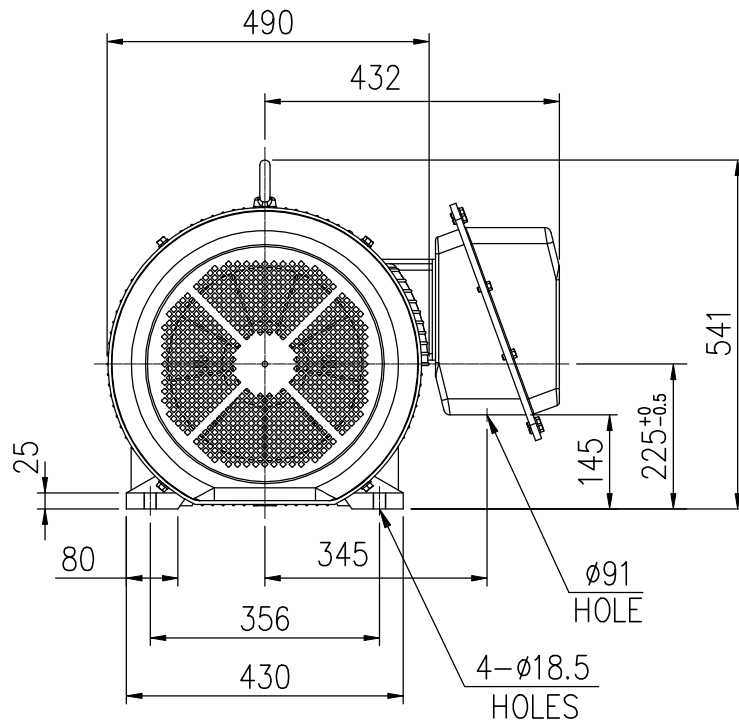

NOTE: 1. F CLASS INSULATION.
2. FOR DIRECT COUPLING.

BEARING NO.		APPROX
D.E	O.D.E	WEIGHT
6314ZZC3	6312ZZC3	370 kg

初步圖面，僅供參考

CERTIFIED BY: _____		DATE: _____	
DESIGNED	Stone CHANG	DWG. NO: AS-030139	REV.
CHECKED	Eagle HUNG	3RD ANGLE PROJECTION	
APPROVED	Eagle HUNG	DIMENSION IN mm	



00