

OUTLINE
3-PHASE
INDUCTION MOTOR

TOTALLY ENCLOSED FAN
COOLED, SQUIRREL CAGE
ROTOR (INDOOR)
HIGH EFFICIENCY
TS21F SERIES

FILE NO:
CUSTOMER:
PO. NO:
ORDER NO:

OUTPUT	POLE	SYN. SPEED	VOLT.	FREQ	INSUL.	TIME RATING	MODEL	FRAME NO.
	2				F	S1	FHFC-HD	280M

- * IE3 EFFICIENCY
- * FOR DIRECT COUPLING

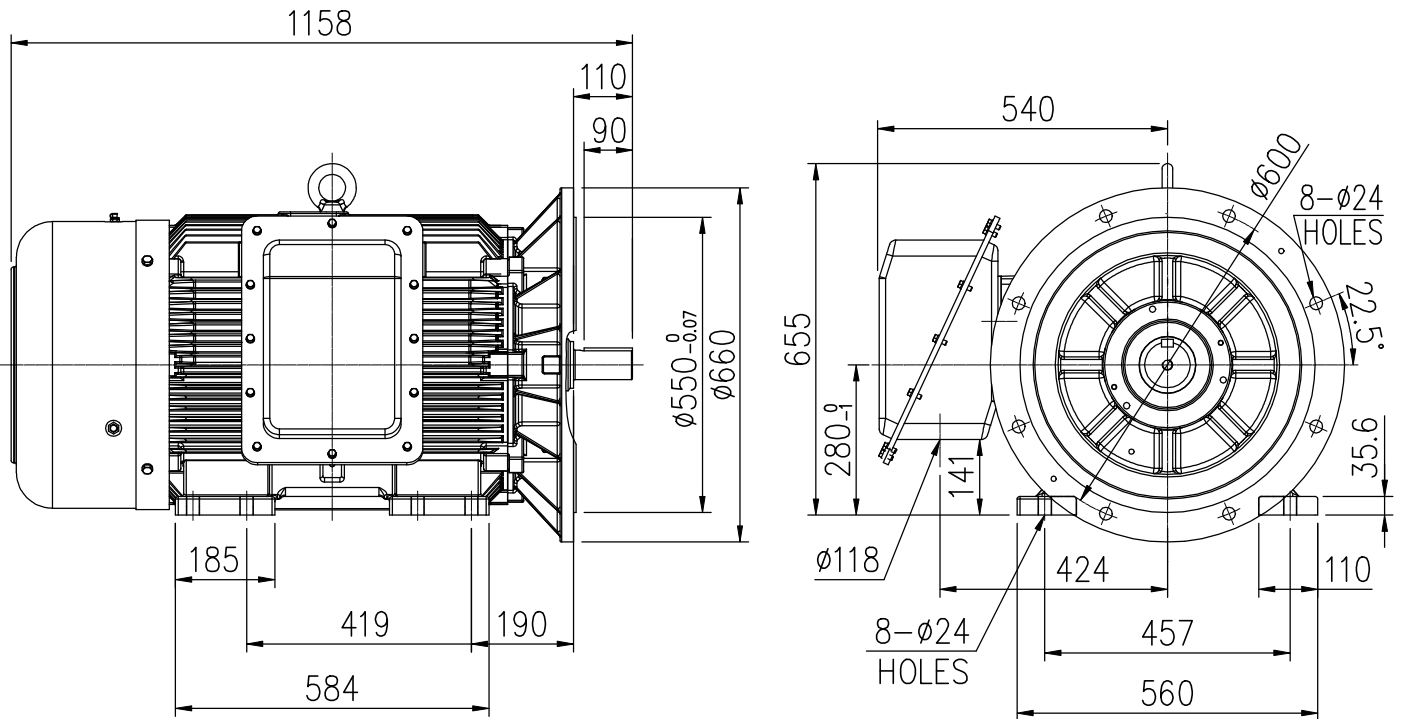

BEARING NO.		APPROX WEIGHT
D.E	O.D.E	
6316ZC3	6316ZC3	850 kg



DESIGNED	CC LIU DEC.30,2017	DWG. NO: AS-064114	REV.
CHECKED	LJ LEE DEC.30,2017	DIMENSION IN mm	00
APPROVED	LJ LEE DEC.30,2017	3RD ANGLE PROJECTION	