

OUTLINE 3-PHASE INDUCTION MOTOR

TOTALLY ENCLOSED FAN
COOLED, SQUIRREL CAGE
ROTOR (90 SERIES)

FILE NO:

CUSTOMER:

PO. NO:

ORDER NO:

OUTPUT	POLE	SYN. SPEED	VOLT.	FREQ	TIME RATING	MODEL	FRAME NO.
	2P				S1	FHFC-HD	180M

** IE3 EFFICIENCY
** FOR DIRECT COUPLING

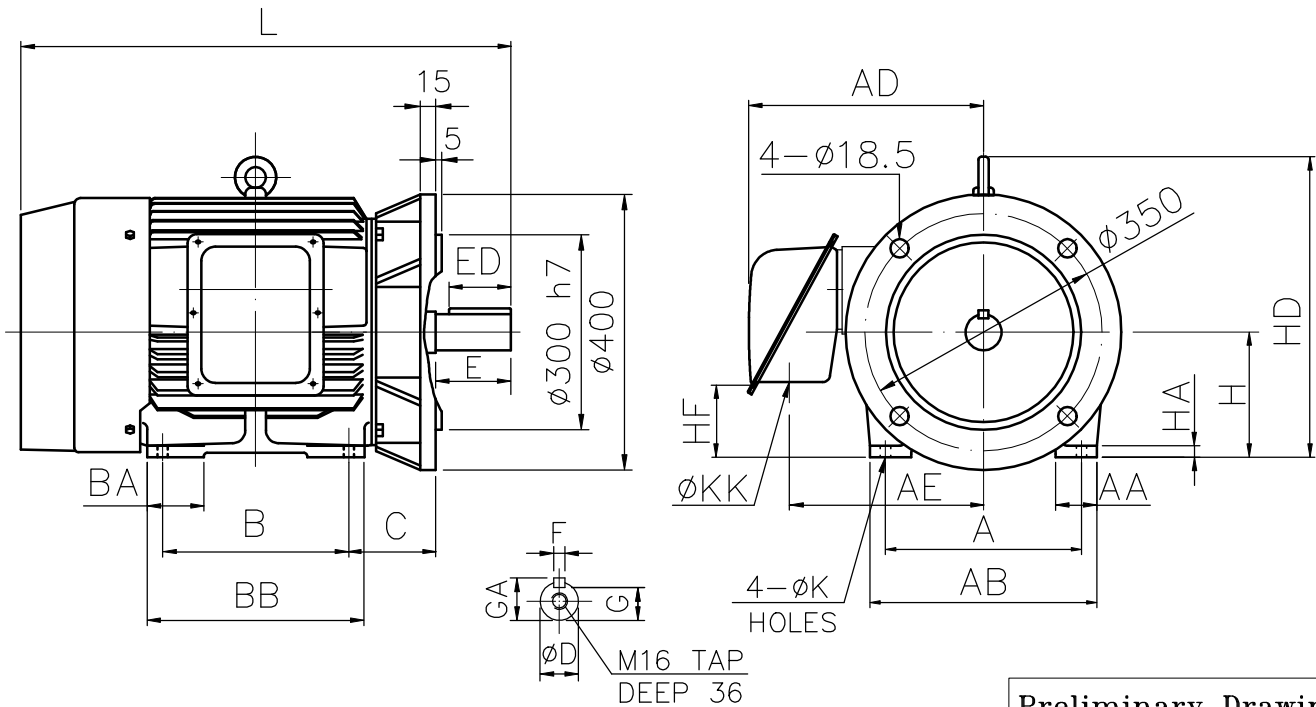

Preliminary Drawing
For Reference Only

A	B	C	H	K	L	AA	AB	AC	AD	AE	BA	BB	HA
279	241	121	180	14.5	676.5	60	324	398	340	280	82.5	286	20

HD	HF	KK	SHAFT END						BEARING NO.		APPROX WEIGHT	
			D	E	ED	F	G	GA	D.E	O.D.E		
440	105	63	48	110	90	14	42.5	51.5		6310ZZ	6210ZZ	193kg

NOTE: 1. TOLERANCE OF SHAFT END DIAMETER D: k6
 2. TOLERANCE OF SHAFT CENTER HEIGHT H: +0, -0.5
 3. F CLASS INSULATION.

CERTIFIED BY : _____ DATE : _____

DESIGNED	S.L.TSAI JAN.03,2019	DWG. NO: AS-064027
CHECKED	L.J.LEE JAN.03,2019	3RD ANGLE PROJECTION
APPROVED	L.J.LEE JAN.03,2019	DIMENSIONS IN mm

