

OUTLINE 3-PHASE INDUCTION MOTOR

TOTALLY ENCLOSED FAN
COOLED, SQUIRREL CAGE
ROTOR

FILE NO:

CUSTOMER:

PO. NO:

ORDER NO:

OUTPUT	POLE	SYN. SPEED R.P.M	VOLT. V	FREQ Hz	INSUL. F	TIME RATING S1	MODEL FHFC-HD	FRAME NO. 90L
--------	------	---------------------	------------	------------	-------------	-------------------	------------------	------------------

** IE3 EFFICIENCY
** FOR DIRECT COUPLING

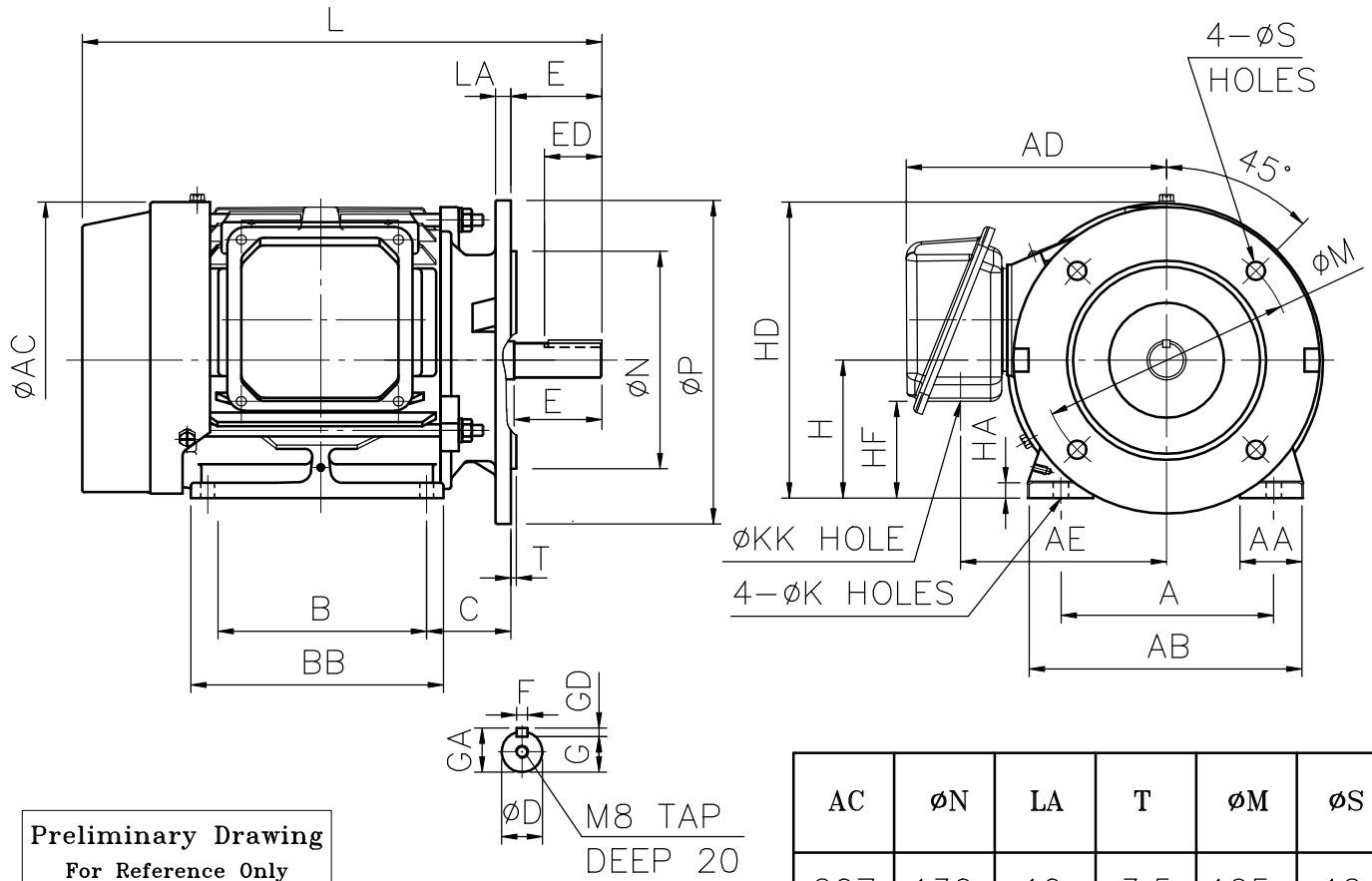

Preliminary Drawing
For Reference Only

AC	øN	LA	T	øM	øS
207	130	10	3.5	165	12

A	B	C	H	øK	L	AA	AB	øP	AD	AE	AF	BB	HA
140	125	56	90	10	327	40	176	200	164	128	--	149	10

HD	HF	øKK	SHAFT END							BEARING NO.		APPROX WEIGHT
			øD	E	ED	F	G	GD	GA	D.E	O.D.E	
194	79	22	24	50	40	8	20	7	27	6205zz	6205zz	28 kg

NOTE: 1.TOLERANCE OF SHAFT END DIAMETER øD : j6(+0.09, -0.004).
2.TOLERANCE OF SHAFT CENTER HEIGHT H : +0, -0.5

CERTIFIED BY :		DATE :	
DESIGNED	S.L.TSAI JAN.03,2019	DWG. NO: AS-073768	
CHECKED	L.J.LEE JAN.03,2019	3RD ANGLE PROJECTION	
APPROVED	L.J.LEE JAN.03,2019	DIMENSIONS IN mm	

