

OUTLINE 3-PHASE INDUCTION MOTOR

TOTALLY ENCLOSED FAN
COOLED, SQUIRREL CAGE
ROTOR (WMP-90)

FILE NO:

CUSTOMER:

PO. NO:

ORDER NO:

OUTPUT	POLE	SYN. SPEED R.P.M	VOLT. V	FREQ Hz	INSUL. F	TIME RATING S1	MODEL FHFC-HD	FRAME NO. 112M

** IE3 EFFICIENCY
** FOR DIRECT COUPLING

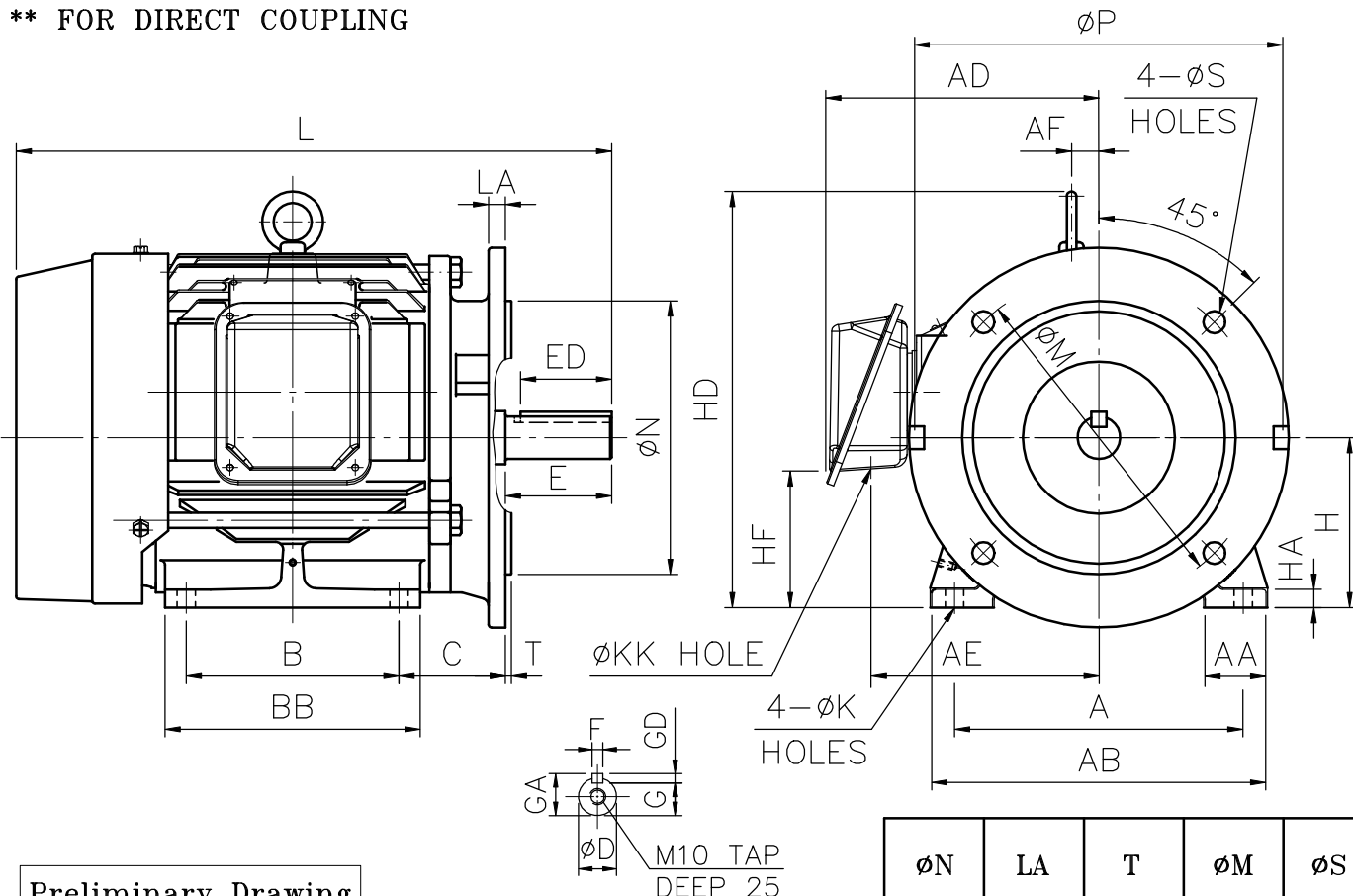

Preliminary Drawing
For Reference Only

øN	LA	T	øM	øS
180	11	4	215	14.5

A	B	C	H	øK	L	AA	AB	øP	AD	AE	AF	BB	HA
190	140	70	112	12	382	40	220	250	180	150	18	168	12

HD	HF	øKK	SHAFT END							BEARING NO.		APPROX WEIGHT
			øD	E	ED	F	G	GD	GA	D.E	O.D.E	
274	90	28	28	60	50	8	24	7	31	6207zz	6206zz	46 kg

NOTE: 1. TOLERANCE OF SHAFT END DIAMETER D: j6 (+0.009, -0.004)

2. TOLERANCE OF SHAFT CENTER HEIGHT H: +0, -0.5



CERTIFIED BY : _____ DATE : _____

DESIGNED	S.L.TSAI JAN.03,2019	DWG. NO: AS-073770
CHECKED	L.J.LEE JAN.03,2019	3RD ANGLE PROJECTION
APPROVED	L.J.LEE JAN.03,2019	DIMENSIONS IN mm