

**OUTLINE**  
**3-PHASE**  
**INDUCTION MOTOR**

TOTALLY ENCLOSED FAN  
COOLED, SQUIRREL CAGE  
ROTOR  
PREMIUM EFFICIENCY  
IE3 SERIES

FILE NO:  
CUSTOMER:  
PO. NO:  
ORDER NO:

OUTPUT	POLE	SYN. SPEED	VOLT.	FREQ	TIME RATING	MODEL	FRAME NO.
					S1	FHFC-DW	315LL

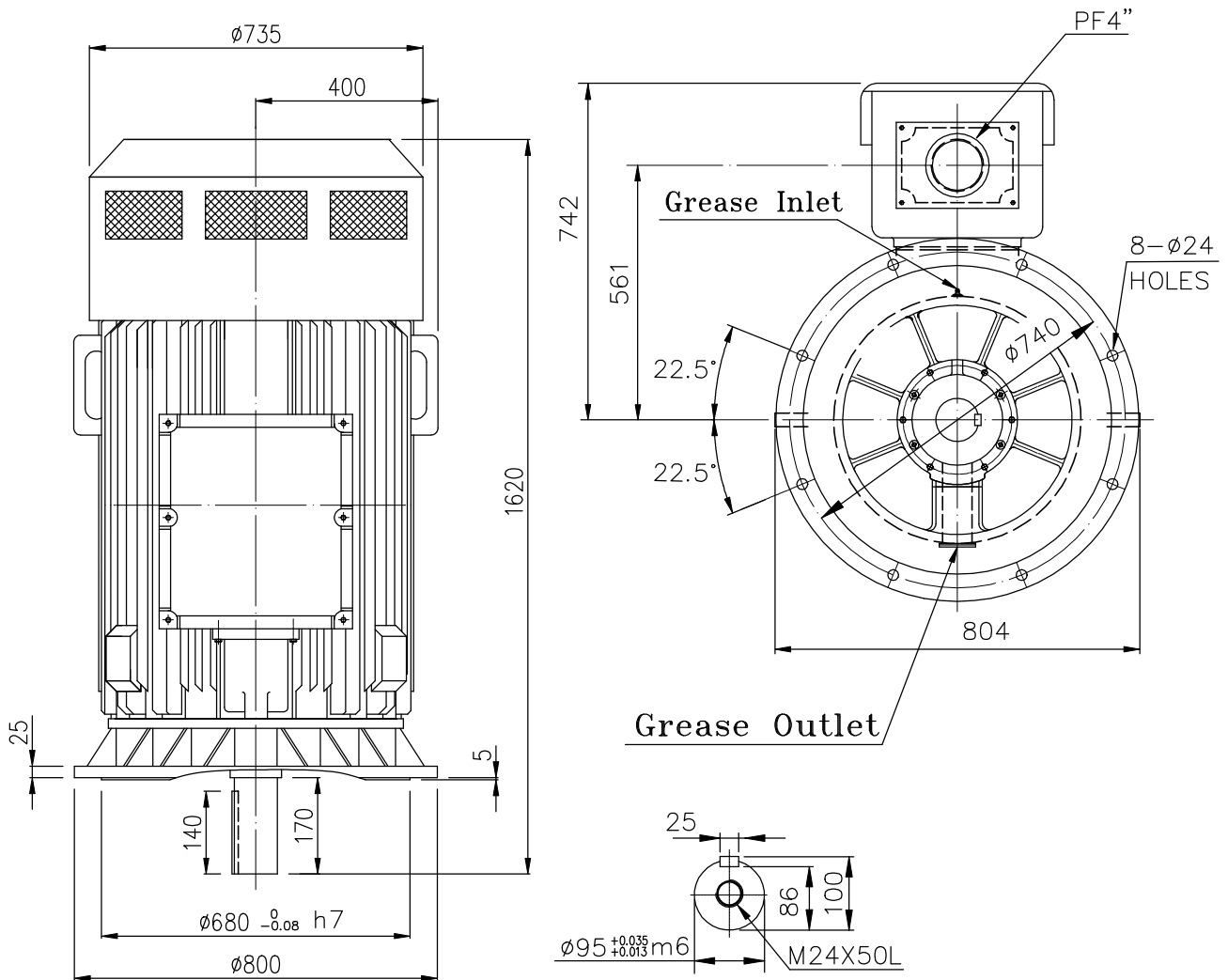

NOTE: 1. F CLASS INSULATION.  
2. FOR DIRECT COUPLING.

BEARING NO.		APPROX
D.E	O.D.E	WEIGHT
6320	6318	1950 kg

初步圖面 僅供參考



CERTIFIED BY: _____		DATE: _____	
DESIGNED	C.Y. CHANG	DWG. NO: AS-032876	REV.
CHECKED	Eagle HUNG	3RD ANGLE PROJECTION	⓪
APPROVED	Eagle HUNG	DIMENSION IN mm	