

<b>OUTLINE</b>  <b>3-PHASE</b> <b>INDUCTION MOTOR</b>	<b>TOTALLY ENCLOSED</b> <b>FAN COOLED</b>  <b>SQUIRREL CAGE ROTOR</b>  <b>(OUTDOOR)</b>	<b>FILE NO:</b>
		<b>CUSTOMER:</b> <b>PO. NO:</b> <b>ORDER NO:</b>

OUTPUT	POLE	SYN. SPEED	VOLT.	FREQ	INSUL.	TIME RATING	MODEL	FRAME NO.
	2				F	S1	FHFC-HD	315M

- \* IE3 Efficiency
- \* Direct Coupled

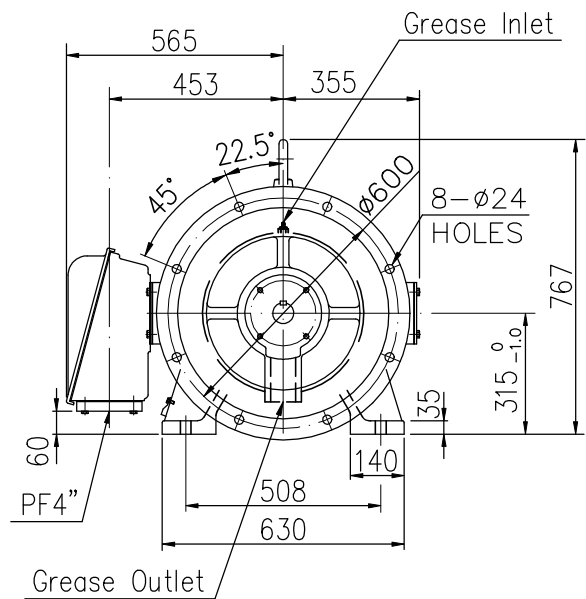
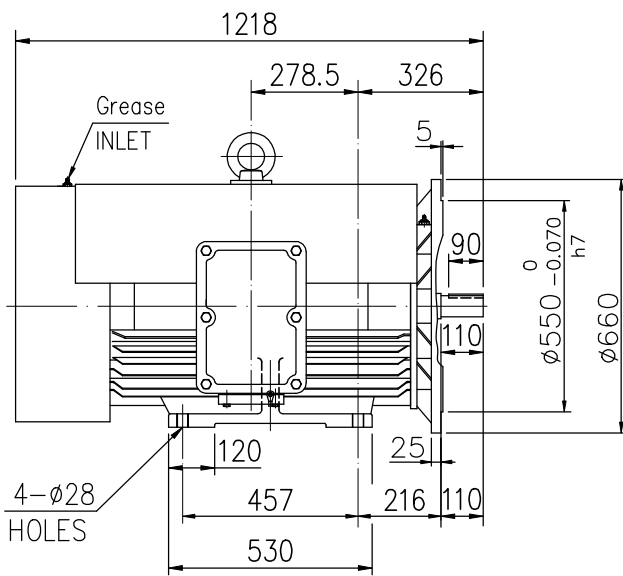

TOLERANCE

KEY WIDTH h9  $\begin{matrix} 0 \\ -0.043 \end{matrix}$

KEY WAY N9  $\begin{matrix} 0 \\ -0.043 \end{matrix}$

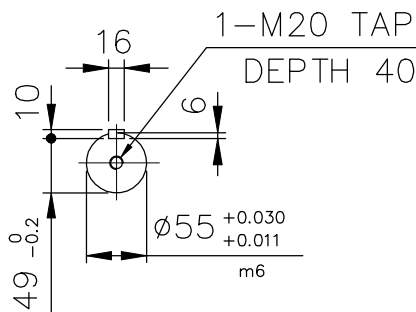

**Preliminary Drawing  
For Reference Only**

HISTORY	
△	

Note:

- 1) Approximate weight = 1170 kg
- 2) Drive end bearing: 6314C3  
Opposite drive end bearing: 6313C3



			REV.
DESIGNED	F.M.SUE DEC, 15, 2017	DWG NO: AS-063905	(00)
CHECKED	L.J. LEE DEC, 15, 2017	3RD ANGLE PROJECTION	
APPROVED	L.J. LEE DEC, 15, 2017	DIMENSIONS IN mm	