

EXPLOSION-PROOF MOTORS

SQUIRREL-CAGE INDUCTION

ENCLOSURE: TOTALLY ENCLOSED
HORIZONTAL: FOOT-MOUNTED

CAST IRON FRAME
FRAME 447TS

COOLING: FAN COOLED
CLASS I , DIVISION I , GROUP D.
CLASS II , DIVISION I , GROUP E,F & G

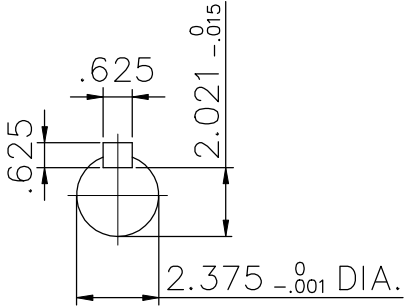
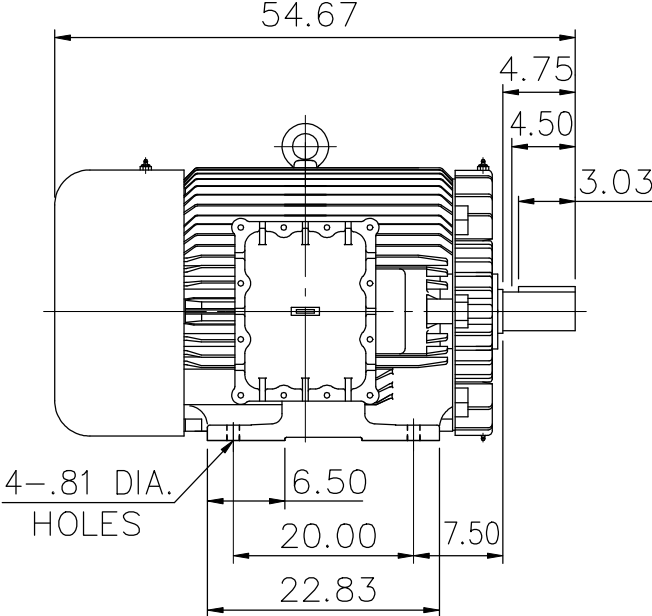
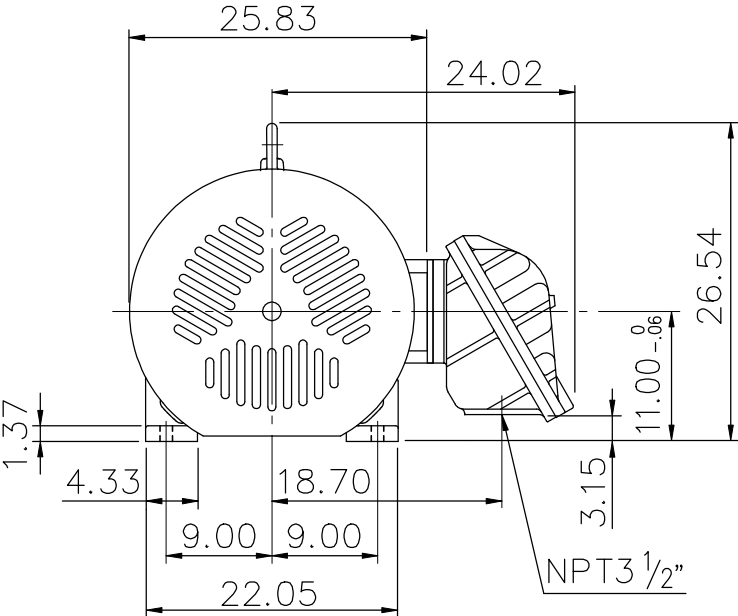

- (1) DIMENSIONS ARE IN INCHES.
- (2) APPROXIMATE WEIGHT= 2892 LBS
- (3) INTERNAL VOLUME OF CONDUIT BOX= 743.4 CU, IN.
- (4) DRIVE END BEARING 6314C3
OPPOSITE DRIVE END BEARING 6314C3
- (5) ALL DATA SUBJECT TO CHANGE WITHOUT NOTICE
- (6) FOR CONSTRUCTION USE ONLY CERTIFIED DATA

Preliminary Drawing for Reference Only

| OUTPUT | POLE | SYN. SPEED | VOLT | FREQ. | CERTIFIED BY _____ DATE _____ | |
|--------|------|------------|------|-------|-------------------------------|---------------|
| | | | | | DR. BY | W. D. KUD |
| | | | | | CK. BY | L. J. LEE |
| | | | | | APP. BY | T. M. LIAD |
| | | | | | DATE | NOV. 27, 2008 |
| | | | | | DIMENSION SHEET | AS-968634 |