

OUTLINE 3-PHASE INDUCTION MOTOR

TOTALLY ENCLOSED FAN
COOLED, SQUIRREL CAGE
ROTOR

FILE NO:
CUSTOMER:
PO. NO:
ORDER NO:

OUTPUT	POLE	SYN. SPEED	VOLT.	FREQ	TIME RATING	MODEL	FRAME NO.
					CONT.	TEFC-DXX	215TC

- * Class I , Division I , Group D
- * Class II , Division I , Group E, F & G

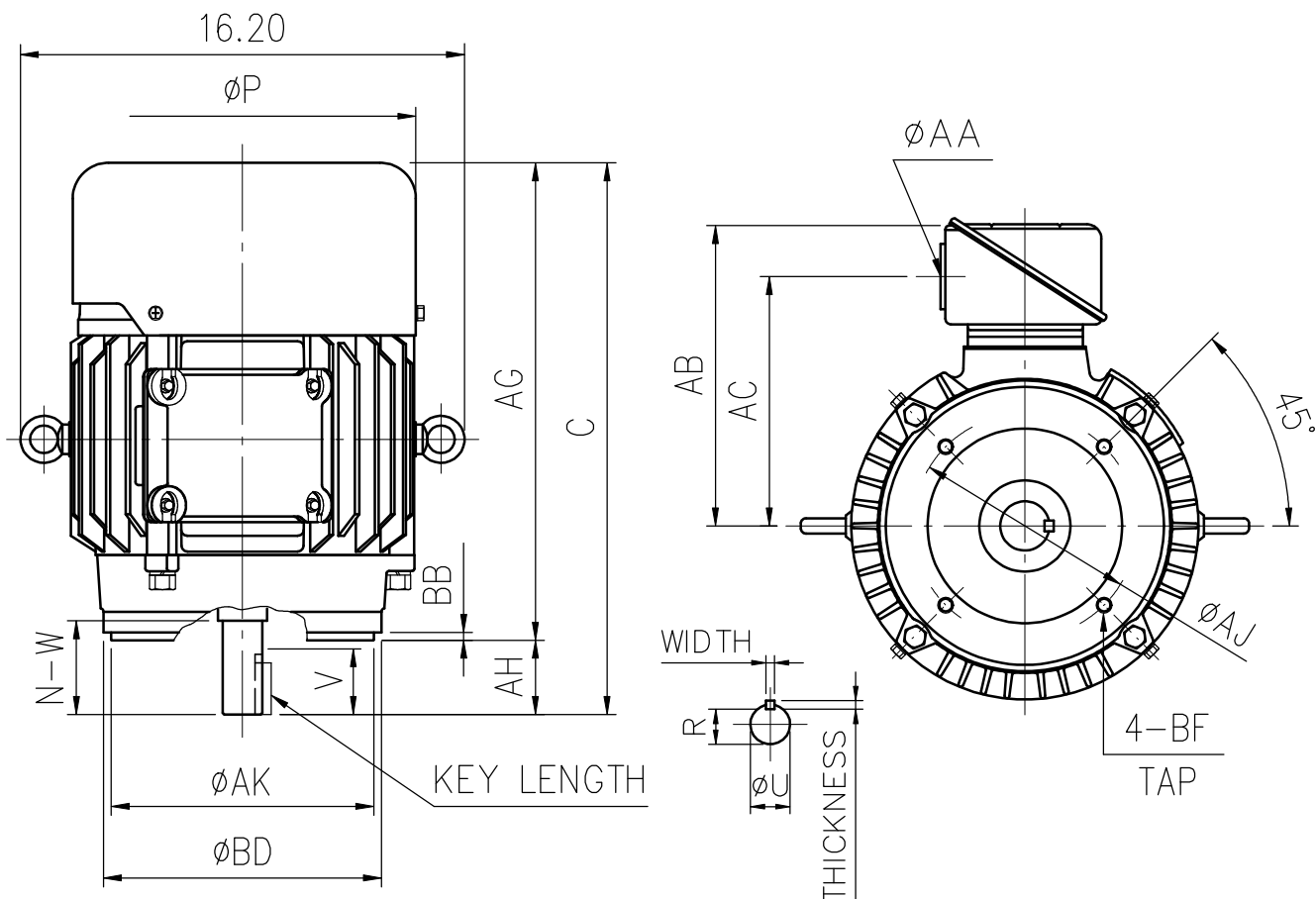

P	C	AG	BF	BB	BD	AK	AH	AJ	AC	SHAFT EXTENSION		
										N-W	U	V
11.97	20.86	17.74	1/2-13	0.25	9.00	8.50	3.12	7.250	8.43	3.38	1.375	3.30

CONDUIT BOX		KEY			KEY SEAT	BEARING NO.		APPROX WT.
AA	AB	WIDTH	THICKNESS	LENGTH	R	D.E.	O.D.E.	
NPT1"	10.51	0.312	0.312	2.375	1.201	6308ZZ	6208ZZ	280 lb

- NOTE:** 1. TOLERANCE ON DIMENSION ϕU : +0.000 inch, -0.0005 inch.
 2. TOLERANCE ON DIMENSION ϕAK : +0.000 inch, -0.003 inch.
 3. DIMENSION V IS LENGTH OF STRAIGHT PART SHAFT. Preliminary Drawing for Reference Only
 4. F CLASS INSULATION

CERTIFIED BY : _____ DATE : _____

DESIGNED	W. D. KUO	DWG. NO: AS-975053
CHECKED	L. J. LEE	3RD ANGLE PROJECTION
APPROVED	T. M. LIAO	DIMENSIONS IN inch

