

OUTLINE 3-PHASE INDUCTION MOTOR

TOTALLY ENCLOSED FAN
COOLED, SQUIRREL CAGE
ROTOR

FILE NO:

CUSTOMER:

PO. NO:

ORDER NO:

OUTPUT	POLE	SYN. SPEED	VOLT.	FREQ	TIME RATING	MODEL	FRAME NO.
					CONT.	TEFC	447TSC

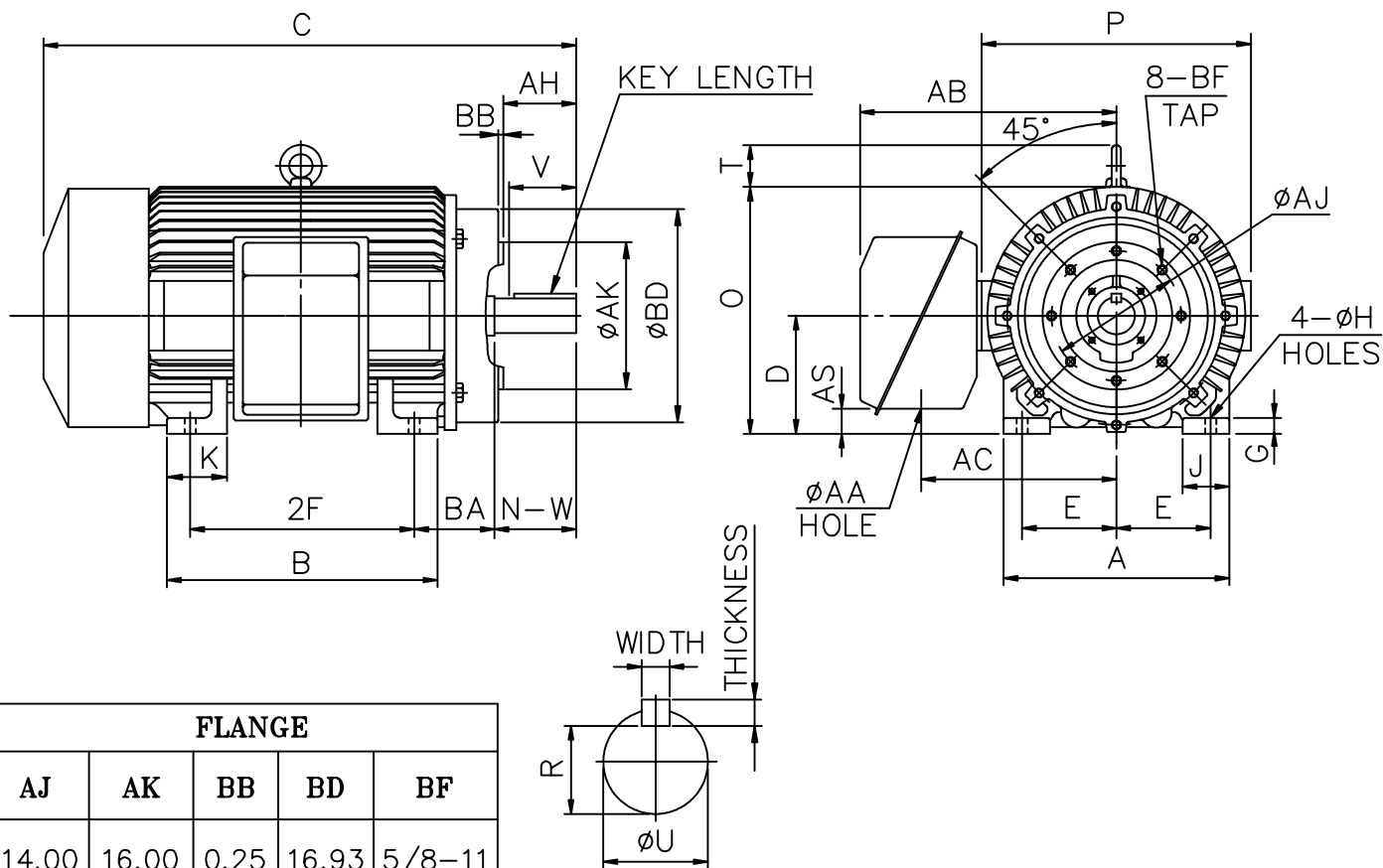

FLANGE				
AJ	AK	BB	BD	BF
14.00	16.00	0.25	16.93	5/8-11

A	B	C	D	E	2F	G	H	J	K	O+T	P	AA	AB	AH
22.05	22.83	53.80	11.00	9.00	20.00	1.18	0.83	4.33	5.71	27.83	26.77	4.65	22.95	4.50

AC	AS	BA	KEY			KEYSEAT	SHAFT EXTENSION			BEARING NO.		APPROX WEIGHT
			WIDTH	THICKNESS	LENGTH		R	N-W	U	V	D.E	
18.03	2.34	7.50	0.625	0.625	3.03	2.021	4.75	2.375	4.50	6313C3	6313C3	2610 lb

- NOTE: 1. TOLERANCE OF SHAFT END DIAMETER U: +0.000, -0.001
 2. TOLERANCE OF SHAFT CENTER HEIGHT D: +0.000, -0.06
 3. DIMENSION R TOLERANCE: +0.000, -0.015
 4. DIMENSION AK TOLERANCE: +0.000, -0.005
 5. DIMENSION V IS LENGTH OF STRAIGHT PART OF SHAFT.
 6. F CLASS INSULATION.

CERTIFIED BY : _____ DATE : _____

DESIGNED W. D. KUO DWG. NO: AS-832468

CHECKED L. J. LEE 3RD ANGLE PROJECTION

APPROVED T. M. LIAO DIMENSION IN inch

