

OUTLINE 3-PHASE INDUCTION MOTOR

TOTALLY ENCLOSED FAN
COOLED, SQUIRREL CAGE
ROTOR

FILE NO:

CUSTOMER:

PO. NO:

ORDER NO:

OUTPUT	POLE	SYN. SPEED	VOLT.	FREQ	TIME RATING	MODEL	FRAME NO.
					CONT.	TEFC	405TSC

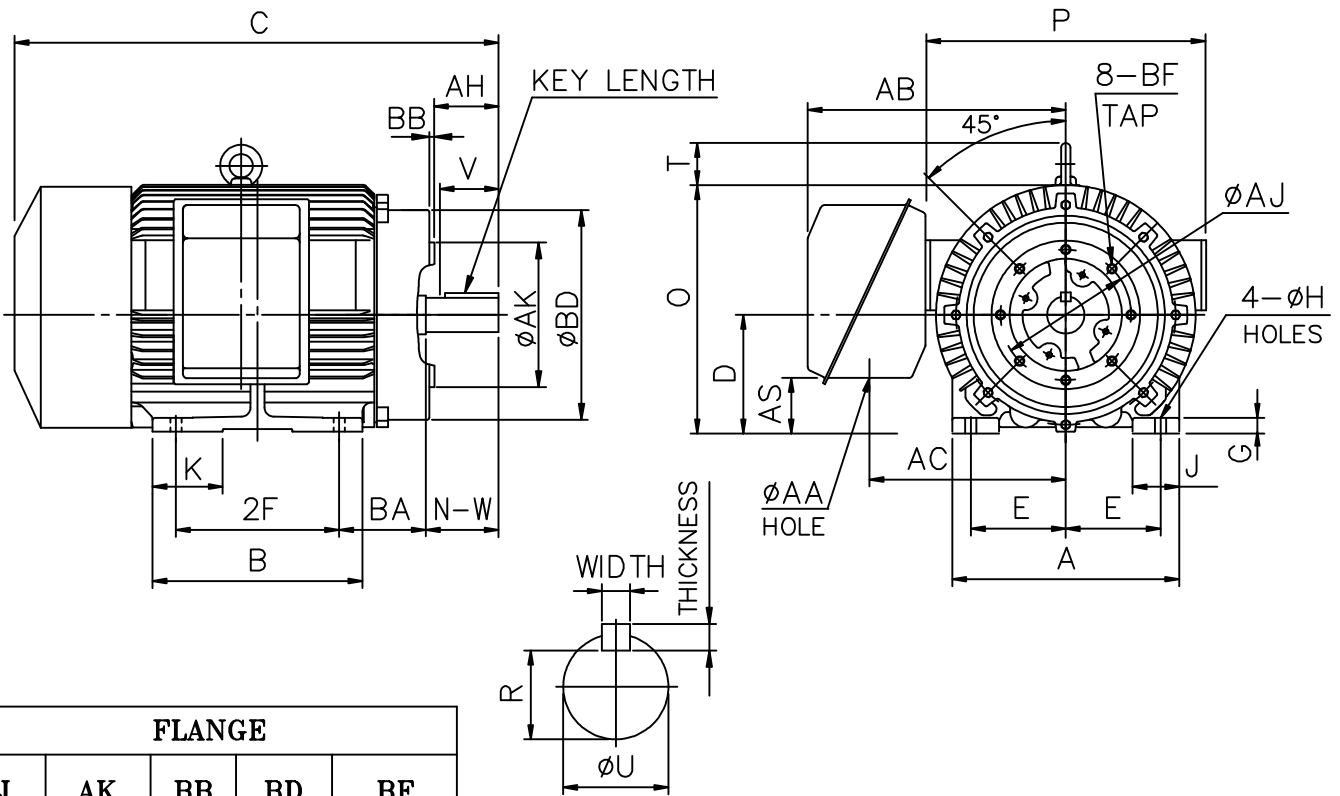

FLANGE				
AJ	AK	BB	BD	BF
11.00	12.50	0.25	15.50	5/8-11

A	B	C	D	E	2F	G	H	J	K	O+T	P	AA	AB	AH
19.13	17.68	37.60	10.00	8.00	13.75	1.34	0.81	3.94	5.91	24.50	23.60	4.65	20.87	7.00

AC	AS	BA	KEY			KEYSEAT R	SHAFT EXTENSION			BEARING NO.		APPROX WEIGHT
			WIDTH	THICKNESS	LENGTH		N-W	U	V	D.E	O.D.E	
16.53	4.53	6.62	0.500	0.500	2.75	1.845	4.25	2.125	4.00	6313C3	6313C3	1460 lb

- NOTE: 1. TOLERANCE OF SHAFT END DIAMETER U: +0.000, -0.001
 2. TOLERANCE OF SHAFT CENTER HEIGHT D: +0.00, -0.06
 3. DIMENSION R TOLERANCE: +0.000, -0.015
 4. DIMENSION AK TOLERANCE: +0.000, -0.005
 5. DIMENSION V IS LENGTH OF STRAIGHT PART OF SHAFT.
 6. F CLASS INSULATION.

CERTIFIED BY : _____ DATE : _____

DESIGNED	W. D. KUO	DWG. NO: AS-832493
CHECKED	L. J. LEE	3RD ANGLE PROJECTION
APPROVED	T. M. LIAO	DIMENSION IN inch

