

OUTLINE 3-PHASE INDUCTION MOTOR

**TOTALLY ENCLOSED FAN
COOLED, SQUIRREL CAGE
ROTOR**

FILE NO:

CUSTOMER:

PO. NO:

ORDER NO:

OUTPUT	POLE	SYN. SPEED	VOLT.	FREQ	TIME RATING	MODEL	FRAME NO.
					CONT.	TEFC	284TC

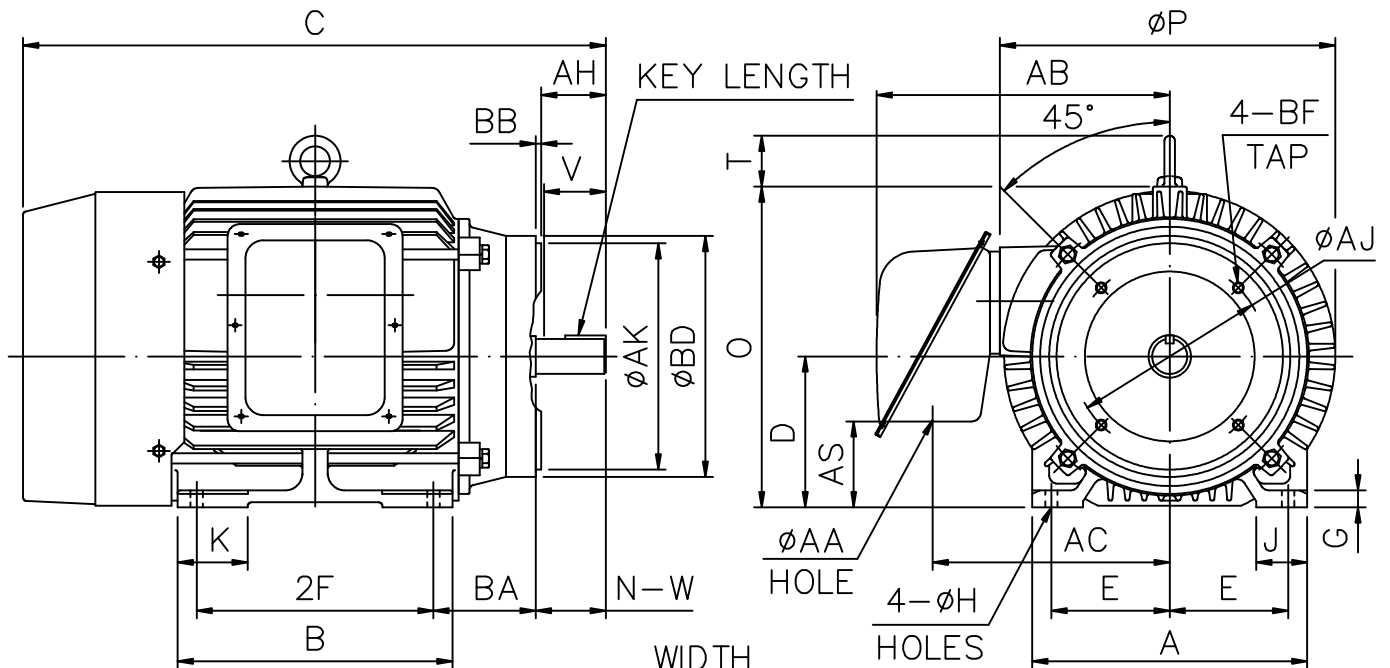

FLANGE

AJ	AK	BB	BD	BF
9.00	10.50	0.25	11.25	1/2-13

A	B	C	D	E	2F	G	H	J	K	O+T	P	AA	AB	AH
12.76	11.26	26.9	7.00	5.50	9.50	0.79	0.53	2.36	3.25	17.30	15.67	2.48	13.4	4.38

AC	AS	BA	KEY			KEYSEAT	SHAFT EXTENSION			BEARING NO.		APPROX WEIGHT
			WIDTH	THICKNESS	LENGTH	R	N-W	U	V	D.E	O.D.E	
11.0	4.05	4.75	0.50	0.50	3.28	1.591	4.62	1.875	4.5	6310ZZ	6210ZZ	403 lb

- NOTE:**
1. TOLERANCE OF SHAFT END DIAMETER U: +0.000, -0.001
 2. TOLERANCE OF SHAFT CENTER HEIGHT D: +0.000, -0.03
 3. DIMENSION R TOLERANCE: +0.000, -0.015
 4. DIMENSION AK TOLERANCE: +0.000, -0.003
 5. DIMENSION V IS LENGTH OF STRAIGHT PART OF SHAFT.
 6. F CLASS INSULATION.

CERTIFIED BY : _____ DATE : _____

DESIGNED	W. D. KUO	DWG. NO: AS-832566
CHECKED	L. J. LEE	3RD ANGLE PROJECTION
APPROVED	T. M. LIAO	DIMENSION IN inch

