

OUTLINE 3-PHASE INDUCTION MOTOR

TOTALLY ENCLOSED FAN
COOLED, SQUIRREL CAGE
ROTOR

FILE NO:

CUSTOMER:

PO. NO:

ORDER NO:

| OUTPUT | POLE | SYN. SPEED | VOLT. | FREQ | TIME RATING | MODEL | FRAME NO. |
|--------|------|------------|-------|------|-------------|-------|-----------|
| | | | | | CONT. | TEFC | 215TC |

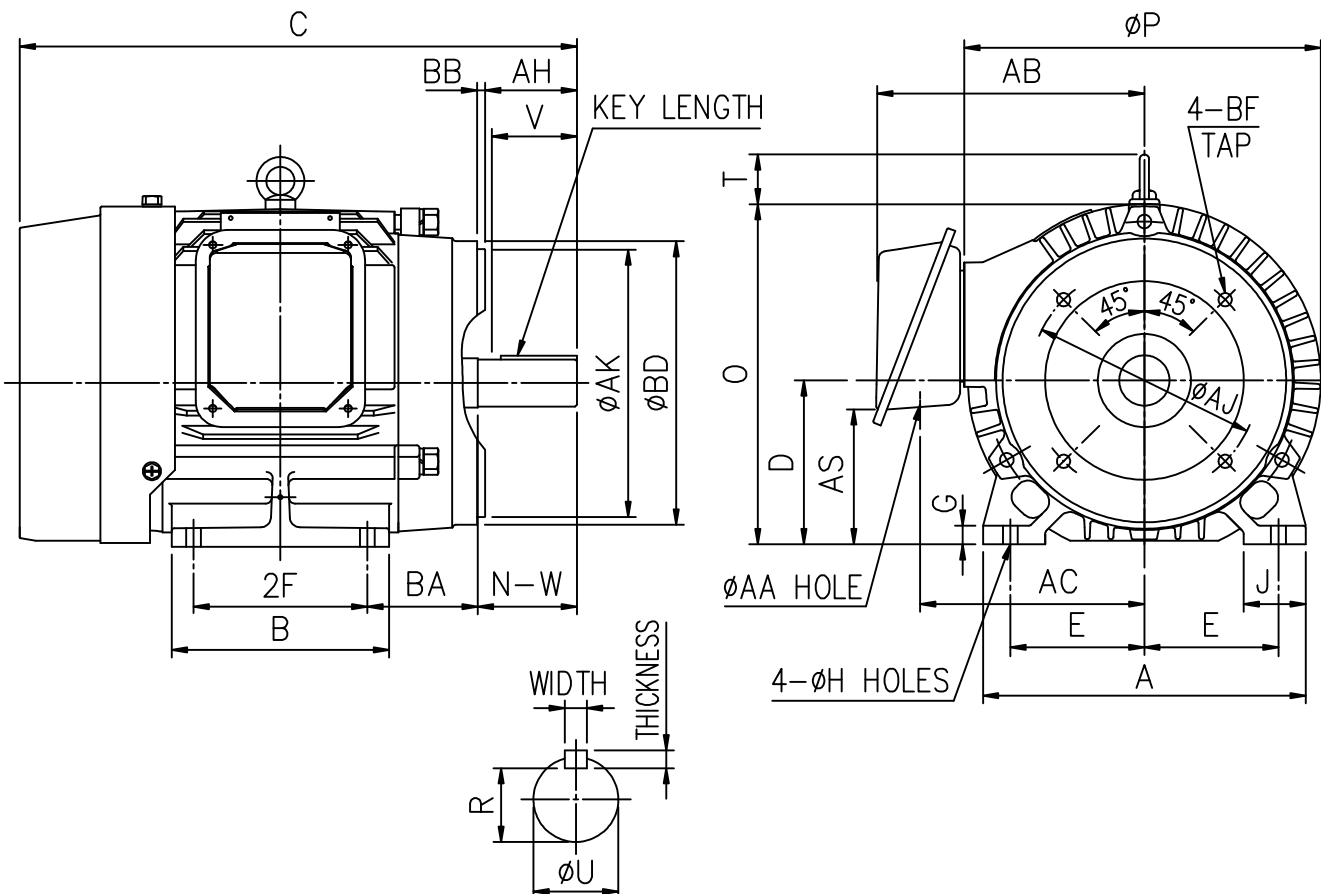

| A | B | C | D | G | J | O | P | T | AJ | AK | BD | BB | BF | AH | MOUNTING | | | |
|-------|------|-------|------|------|------|-------|-------|------|-------|------|------|------|--------|------|----------|------|------|------|
| | | | | | | | | | | | | | | | E | 2F | H | BA |
| 10.23 | 8.39 | 19.43 | 5.25 | 0.65 | 1.97 | 10.84 | 11.20 | 1.65 | 7.250 | 8.50 | 9.00 | 0.25 | 1/2-13 | 3.12 | 4.25 | 7.00 | 0.41 | 3.50 |

| CONDUIT BOX | | | | KEY | | | KEYSEAT | SHAFT EXTENSION | | | BEARING NO. | | APPR. WT. |
|-------------|------|-----|-----|-------|-----------|--------|---------|-----------------|-------|------|-------------|--------|-----------|
| AA | AB | AC | AS | WIDTH | THICKNESS | LENGTH | R | N-W | U | V | D.E | O.D.E | |
| 1.38 | 8.39 | 7.2 | 4.4 | 0.312 | 0.312 | 2.375 | 1.201 | 3.38 | 1.375 | 3.30 | 6308ZZ | 6208ZZ | 162 lb |

- NOTE: 1. TOLERANCE OF SHAFT END DIAMETER U: +0.000, -0.0005
 2. TOLERANCE OF SHAFT CENTER HEIGHT D: +0.000, -0.03
 3. DIMENSION R TOLERANCE: +0.000, -0.015
 4. DIMENSION AK TOLERANCE: +0.000, -0.003
 5. DIMENSION V IS LENGTH OF STRAIGHT PART OF SHAFT.
 6. F CLASS INSULATION.

CERTIFIED BY : _____ DATE : _____

| | | |
|----------|------------|----------------------|
| DESIGNED | W. D. KUO | DWG. NO: AS-840112 |
| CHECKED | L. J. LEE | 3RD ANGLE PROJECTION |
| APPROVED | T. M. LIAO | DIMENSIONS IN inch |

