

OUTLINE 3-PHASE INDUCTION MOTOR

TOTALLY ENCLOSED FAN
COOLED, SQUIRREL CAGE
ROTOR

FILE NO:

CUSTOMER:

PO. NO:

ORDER NO:

OUTPUT	POLE	SYN. SPEED	VOLT.	FREQ	TIME RATING	MODEL	FRAME NO.
					CONT.	TEFC	143TC

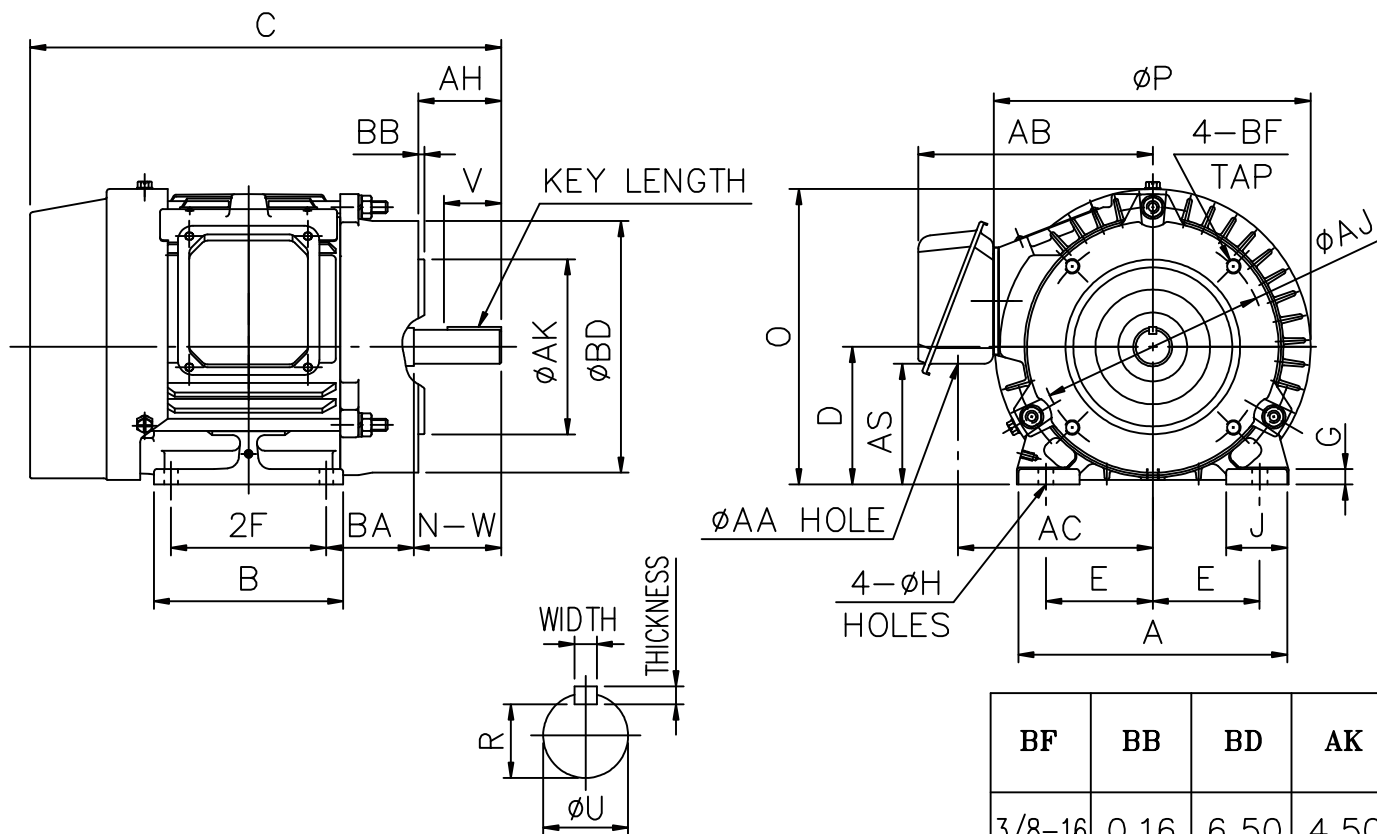

MOUNTING				A	B	C	D	G	J	O	AH	P	AJ
E	2F	H	BA										
2.75	4.00	0.34	2.25	6.93	4.88	12.25	3.50	0.35	1.57	7.57	2.12	8.15	5.875

AC	KEY			KEYSEAT	CONDUIT BOX			SHAFT EXTENSION			BEARING NO.		APR. WT.
	WIDTH	THICKNESS	LENGTH	R	AS	AA	AB	N-W	U	V	D.E	O.D.E	
5.28	0.188	0.188	1.375	0.771	2.63	1.10	6.46	2.25	0.875	2.20	6205ZZ	6205ZZ	44 lb

- NOTE: 1. TOLERANCE OF SHAFT END DIAMETER U: +0.000, -0.0005
 2. TOLERANCE OF SHAFT CENTER HEIGHT D: +0.000, -0.03
 3. DIMENSION R TOLERANCE: +0.000, -0.015
 4. DIMENSION AK TOLERANCE: +0.000, -0.003
 5. DIMENSION V IS LENGTH OF STRAIGHT PART OF SHAFT.
 6. F CLASS INSULATION.

CERTIFIED BY : _____ DATE : _____

DESIGNED W. D. KUO DWG. NO: AS-860498

CHECKED L. J. LEE 3RD ANGLE PROJECTION

APPROVED T. M. LIAO DIMENSIONS IN inch

