

# OUTLINE 3-PHASE INDUCTION MOTOR

**TOTALLY ENCLOSED FAN  
COOLED, SQUIRREL CAGE  
ROTOR**

FILE NO:

CUSTOMER:

PO. NO:

ORDER NO:

OUTPUT	POLE	SYN. SPEED	VOLT.	FREQ	TIME RATING	MODEL	FRAME NO.
					CONT.	TEFC	145TC

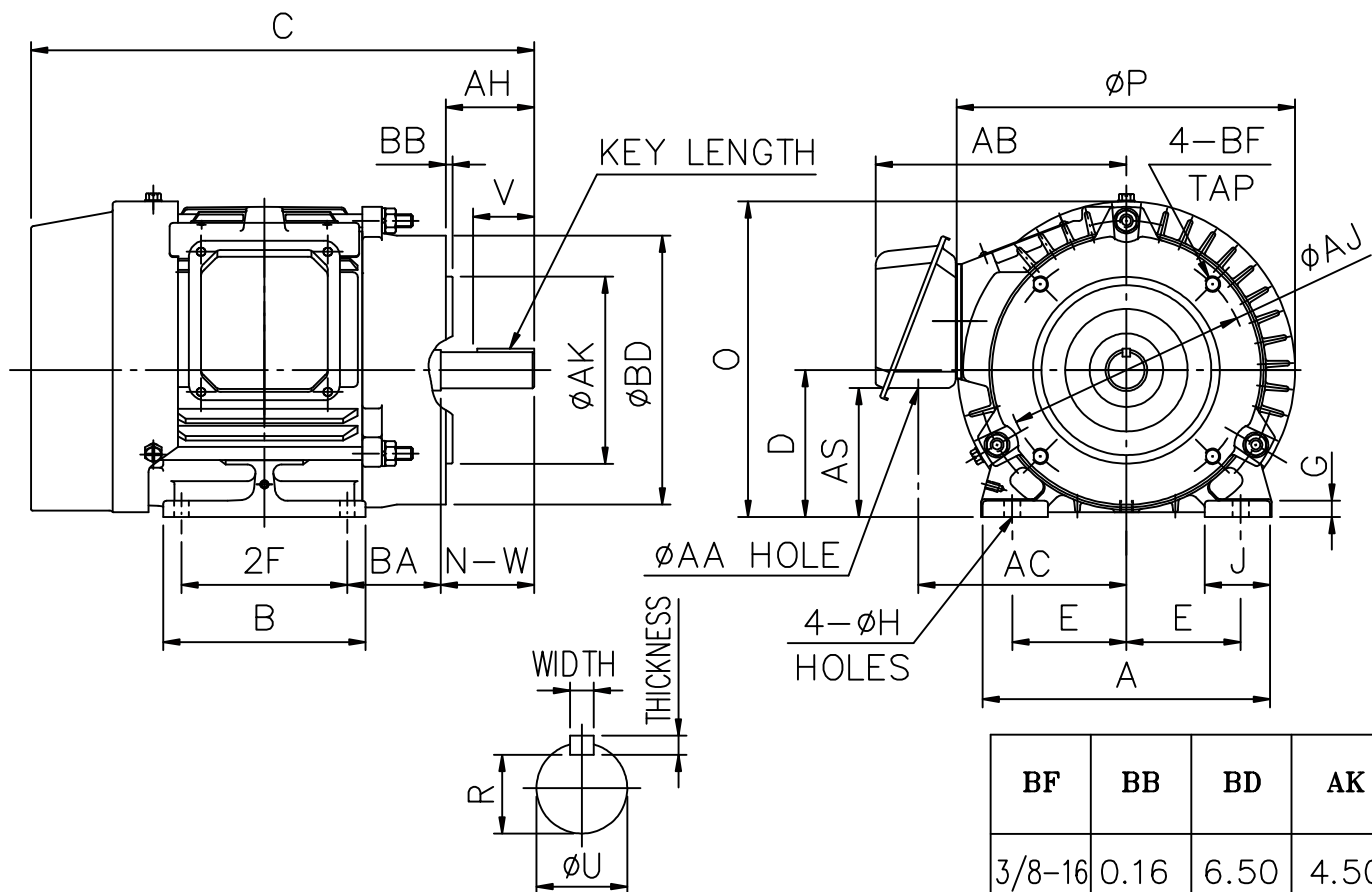

BF	BB	BD	AK
3/8-16	0.16	6.50	4.50

MOUNTING				A	B	C	D	G	J	O	AH	P	AJ
E	2F	H	BA										
2.75	5.00	0.34	2.25	6.93	5.87	13.24	3.50	0.35	1.57	7.57	2.12	8.15	5.875

AC	KEY			KEYSEAT	CONDUIT BOX			SHAFT EXTENSION			BEARING NO.		APR. WT.
	WIDTH	THICKNESS	LENGTH	R	AS	AA	AB	N-W	U	V	D.E	O.D.E	
5.28	0.188	0.188	1.375	0.771	2.63	1.10	6.46	2.25	0.875	2.20	6205ZZ	6205ZZ	55 lb

- NOTE:**
1. TOLERANCE OF SHAFT END DIAMETER U: +0.000, -0.0005
  2. TOLERANCE OF SHAFT CENTER HEIGHT D: +0.000, -0.03
  3. DIMENSION R TOLERANCE: +0.000, -0.015
  4. DIMENSION AK TOLERANCE: +0.000, -0.003
  5. DIMENSION V IS LENGTH OF STRAIGHT PART OF SHAFT.
  6. F CLASS INSULATION.

CERTIFIED BY : _____		DATE : _____	
DESIGNED	W. D. KUO	DWG. NO: AS-860499	
CHECKED	L. J. LEE	3RD ANGLE PROJECTION	
APPROVED	T. M. LIAO	DIMENSIONS IN inch	

