

EXTRA-MAX ALTERNATING CURRENT MOTORS

SQUIRREL-CAGE INDUCTION

ENCLOSURE: OPEN DRIP-PROOF
MOUNTING: FOOT

CAST IRON FRAME
FRAME 213T

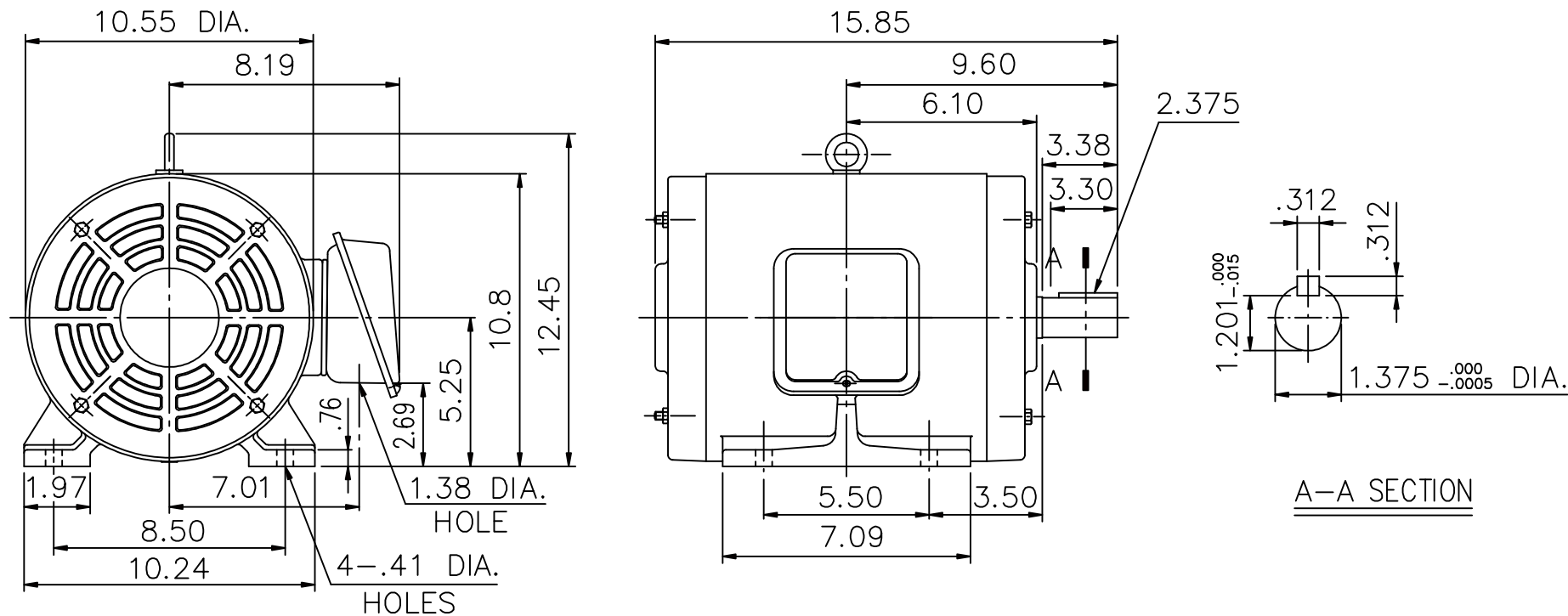

- (1) DIMENSIONS ARE IN INCHES
- (2) APPROXIMATE WEIGHT = 3 HP, 6 P, -140 LBS.
7.5 HP, 4 P, -140 LBS.
10 HP, 2 P, -132 LBS.

- (3) DRIVE END BEARING 6308zz
OPPOSITE DRIVE END BEARING 6208zz
- (4) INTERNAL VOLUME OF CONDUIT BOX = 1.09×10^6 mm³

Preliminary Drawing for Reference Only

OUTPUT	POLE	SYN. SPEED	VOLT	FREQ.	CERTIFIED BY _____ DATE _____
					DR. BY <u>W. D. KUD</u> CK. BY <u>L. J. LEE</u> APP. BY <u>T. M. LIAD</u> DATE <u>NOV. 27, 2008</u>
DIMENSION SHEET					AS-880393 ISSUE DATE JAN. 17, 1998