

# SUPER-MAX ALTERNATING CURRENT MOTORS

SQUIRREL-CAGE INDUCTION

ENCLOSURE: TOTALLY ENCLOSED

MOUNTING: FOOT

CAST IRON FRAME

FRAME 447T/449T

COOLING: FAN COOLED

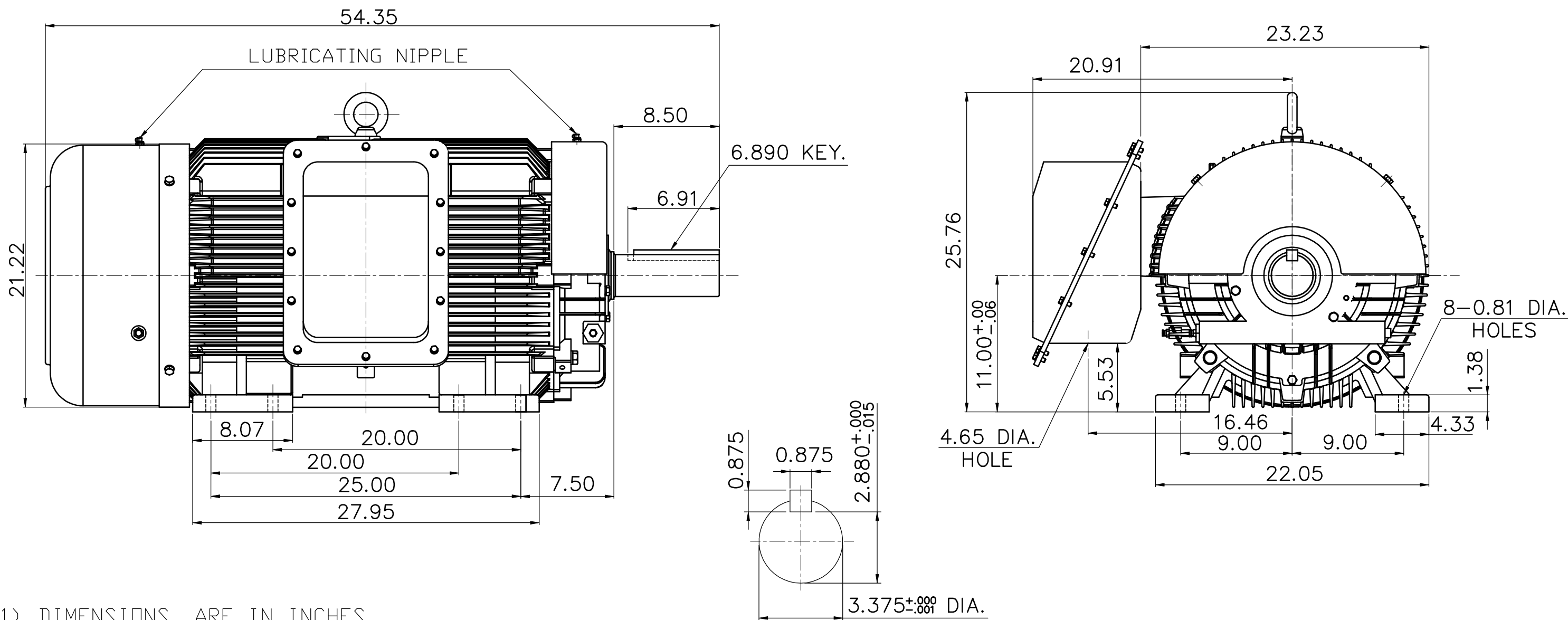

(1) DIMENSIONS ARE IN INCHES.

(2) APPROXIMATE WEIGHT :

200 HP, 4P, 2027LBS 150 HP, 6P, 2054LBS

250 HP, 4P, 2290LBS 200 HP, 6P, 2344LBS

300 HP, 4P, 2488LBS 250 HP, 6P, 2607LBS

(3) DRIVE END BEARING 6320Z/C3

OPPOSITE DRIVE END BEARING 6316Z/C3

(4) INTERNAL VOLUME OF CONDUIT BOX= 1185 CU , IN.

FRAME- \_\_\_\_\_ CERTIFIED FOR- \_\_\_\_\_  
 ORDER- \_\_\_\_\_ ITEM \_\_\_\_\_ HP- \_\_\_\_\_ RPM- \_\_\_\_\_ PH- \_\_\_\_\_ HZ- \_\_\_\_\_ VOLTS- \_\_\_\_\_



DR. BY C. W. CHOU  
 CK. BY L. J. LEE  
 APP. BY L. J. LEE  
 DATE 2016/08/09

DIMENSION SHEET

AS-052630

REV. 00