

SUPER-MAX ALTERNATING CURRENT MOTORS

SQUIRREL-CAGE INDUCTION

ENCLOSURE: TOTALLY ENCLOSED

MOUNTING: FOOT

CAST IRON FRAME

FRAME 447TS/449TS

COOLING: FAN COOLED

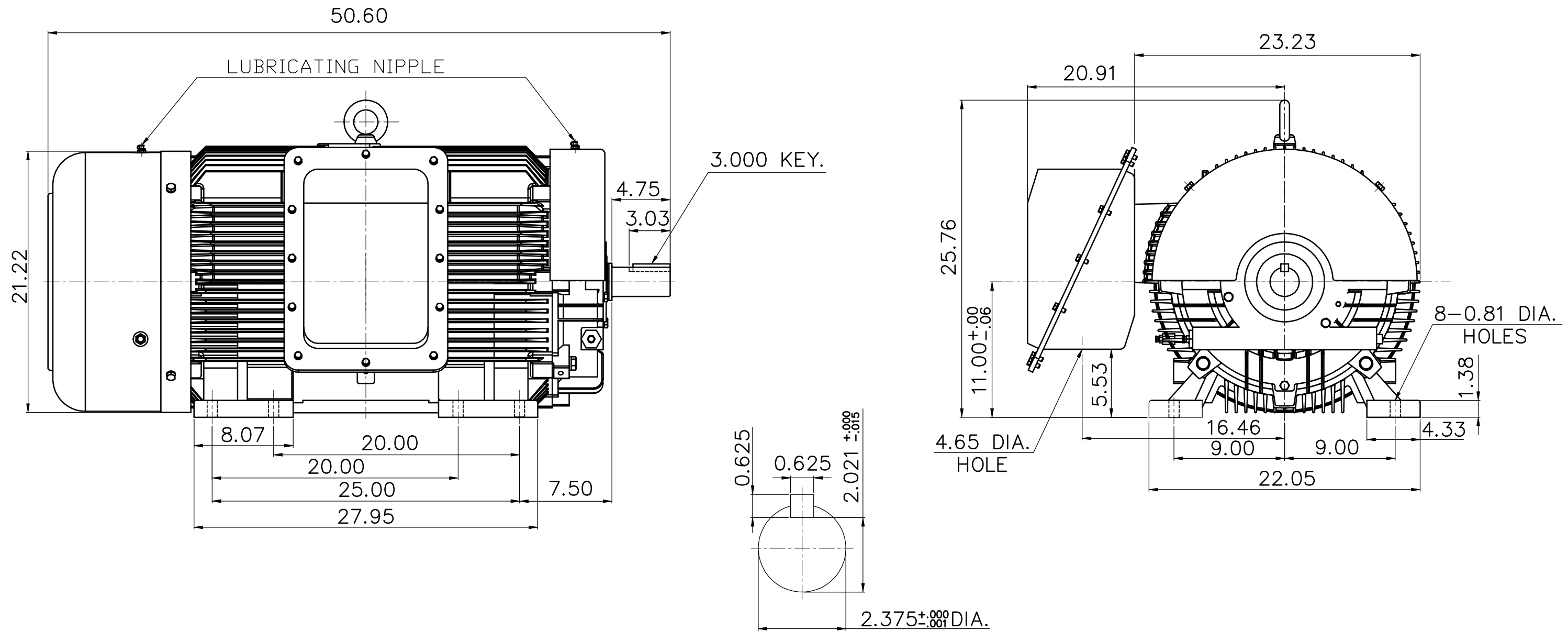

(1) DIMENSIONS ARE IN INCHES.

(2) APPROXIMATE WEIGHT :

200 HP, 2P, 2000LBS 250 HP, 2P, 2150LBS

(3) DRIVE END BEARING 6314Z/C3

OPPOSITE DRIVE END BEARING 6314Z/C3

(4) INTERNAL VOLUME OF CONDUIT BOX= 1185 CU , IN.

FRAME- _____ CERTIFIED FOR- _____

ORDER- _____ ITEM _____ HP- _____ RPM- _____ PH- _____ HZ- _____ VOLTS- _____



DR. BY S. L. TSAI
 CK. BY S. C. CHOU
 APP. BY L. J. LEE
 DATE 2024/02/01

DIMENSION
 SHEET

AS-052633