

OUTLINE 3-PHASE INDUCTION MOTOR	TOTALLY ENCLOSED FAN COOLED SQUIRREL CAGE ROTOR ANTI-FRICTION BEARING	PROJECT NO:
		CUSTOMER: PO. NO: ORDER NO:

OUTPUT	POLE	SYN. SPEED RPM	VOLT. V	FREQ HZ	INSUL. F	TIME RATING CONT.	MODEL TIK-FCKW	FRAME NO. N6310
--------	------	-------------------	------------	------------	-------------	----------------------	-------------------	--------------------

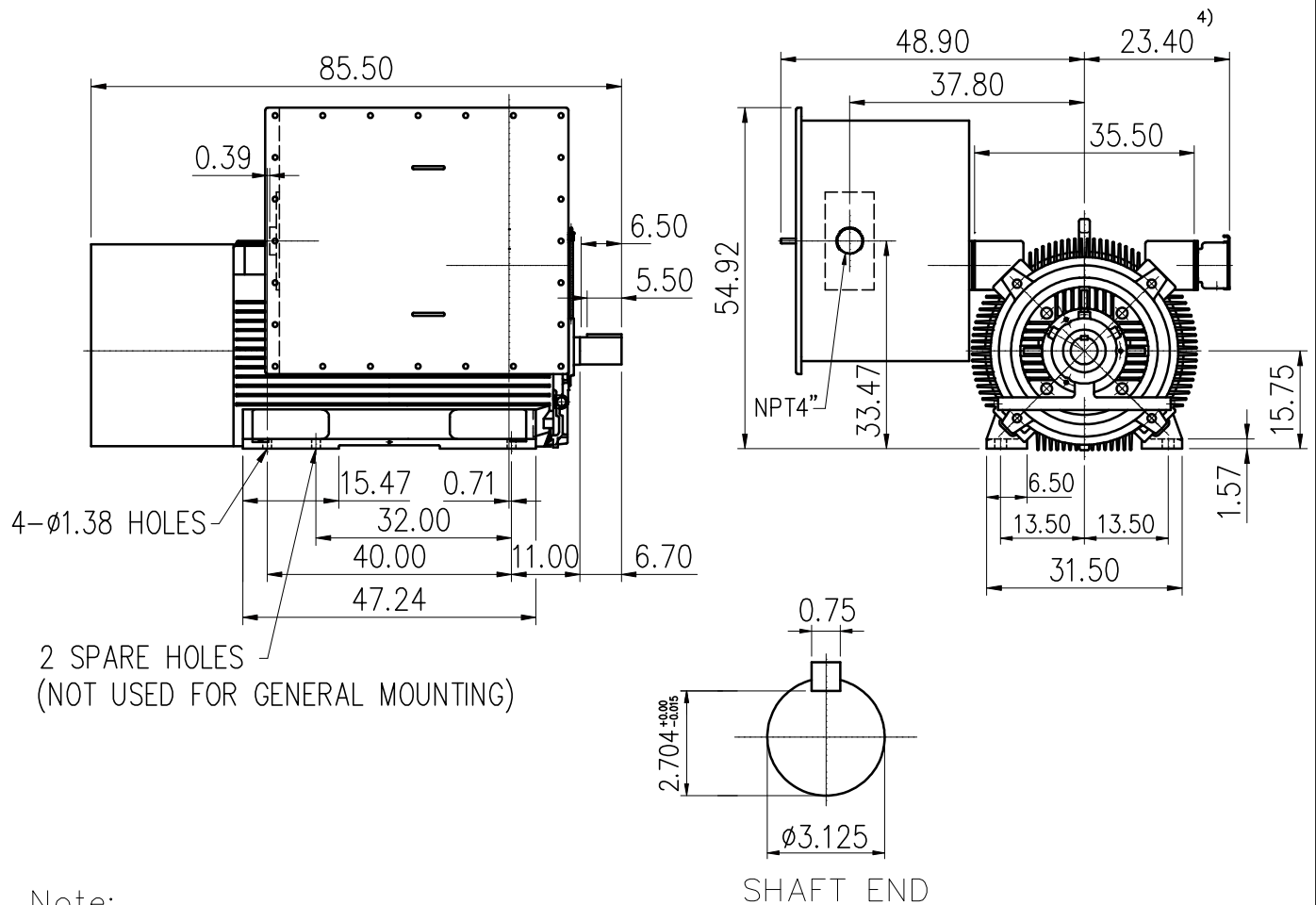

Note:

- 1) Tolerance of shaft center height : +0.00 inch ~ -0.06 inch.
- 2) Tolerance of shaft end diameter : +0.00 inch ~ -0.001 inch.
- 3) For direct coupling.
- 4) Auxiliary terminal box is optional and dependent on specified accessories.
- 5) Approximate weight = 9250 lbs.
- 6) Drive end bearing: 6218C3.
Opposite drive end bearing: 6218C3.
- 7) Direction of rotation : C.W (viewed from non-drive end).

Preliminary Drawing for Reference Only



BASIC DWG NO: AL-FB-5695

CERTIFIED BY:		DATE:
DESIGNED	C.Y.WEN	DIMENSIONS IN inch
CHECKED	T.F.CHENG	3RD ANGLE PROJECTION
APPROVED	T.F.CHENG	DATE: NOV.30.2009