

OUTLINE 3-PHASE INDUCTION MOTOR

TOTALLY ENCLOSED FAN
COOLED, SQUIRREL CAGE
ROTOR

FILE NO:

CUSTOMER:

PO. NO:

ORDER NO:

OUTPUT	POLE	SYN. SPEED	VOLT.	FREQ	TIME RATING	MODEL	FRAME NO.
					CONT.	TEFC-DXX	286TSC

- * CLASS I , DIVISION I , GROUP D
- * CLASS II , DIVISION I , GROUP E, F & G

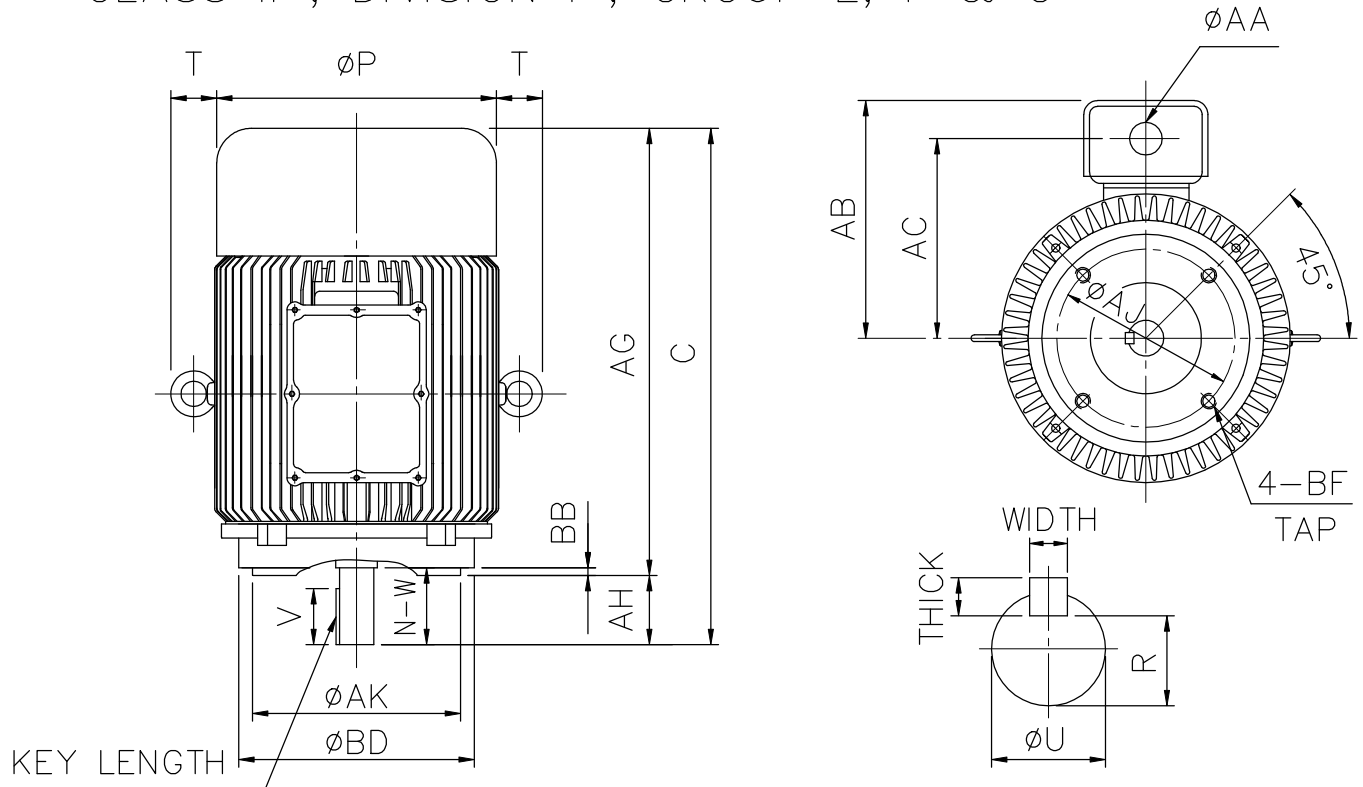

FLANGE						C	P	T	AG	AH	P+2T	AC
AJ	AK	BB		BD	BF							
9.000	10.50	0.25		11.18	1/2-13	26.84	17.36	2	23.83	3.01	21.36	13.10

SHAFT EXTENSION			KEY			KEYSEAT R	TERMINAL BOX		APPROX WEIGHT
N-W	U	V	WIDTH	THICK	LENGTH		AA	AB	
3.25	1.625	3.20	0.375	0.375	1.910	1.416	NPT1 1/2"	17.52	626 lb

- NOTE: 1.TOLERANCE ON DIMENSION AK: +0.000.-0.003 inch
 2.TOLERANCE ON DIMENSION U: +0.000.-0.001 inch
 3.TOLERANCE OF DIMENSION R: +0.000.-0.015 inch
 4. F CLASS INSULATION.

BEARING NO.	
D.E.	O.D.E.
6310C3	6310C3

初步圖面，僅供參考

CERTIFIED BY : _____ DATE : _____

DESIGNED	W. D. KUO	DWG. NO: AS-975042
CHECKED	L. J. LEE	3RD ANGLE PROJECTION
APPROVED	T. M. LIAO	DIMENSION IN inch

