

OUTLINE 3-PHASE INDUCTION MOTOR

TOTALLY ENCLOSED FAN
COOLED, SQUIRREL CAGE
ROTOR

FILE NO:

CUSTOMER:

PO. NO:

ORDER NO:

OUTPUT	POLE	SYN. SPEED	VOLT.	FREQ	TIME RATING	MODEL	FRAME NO.
					CONT.	TEFC	444TC

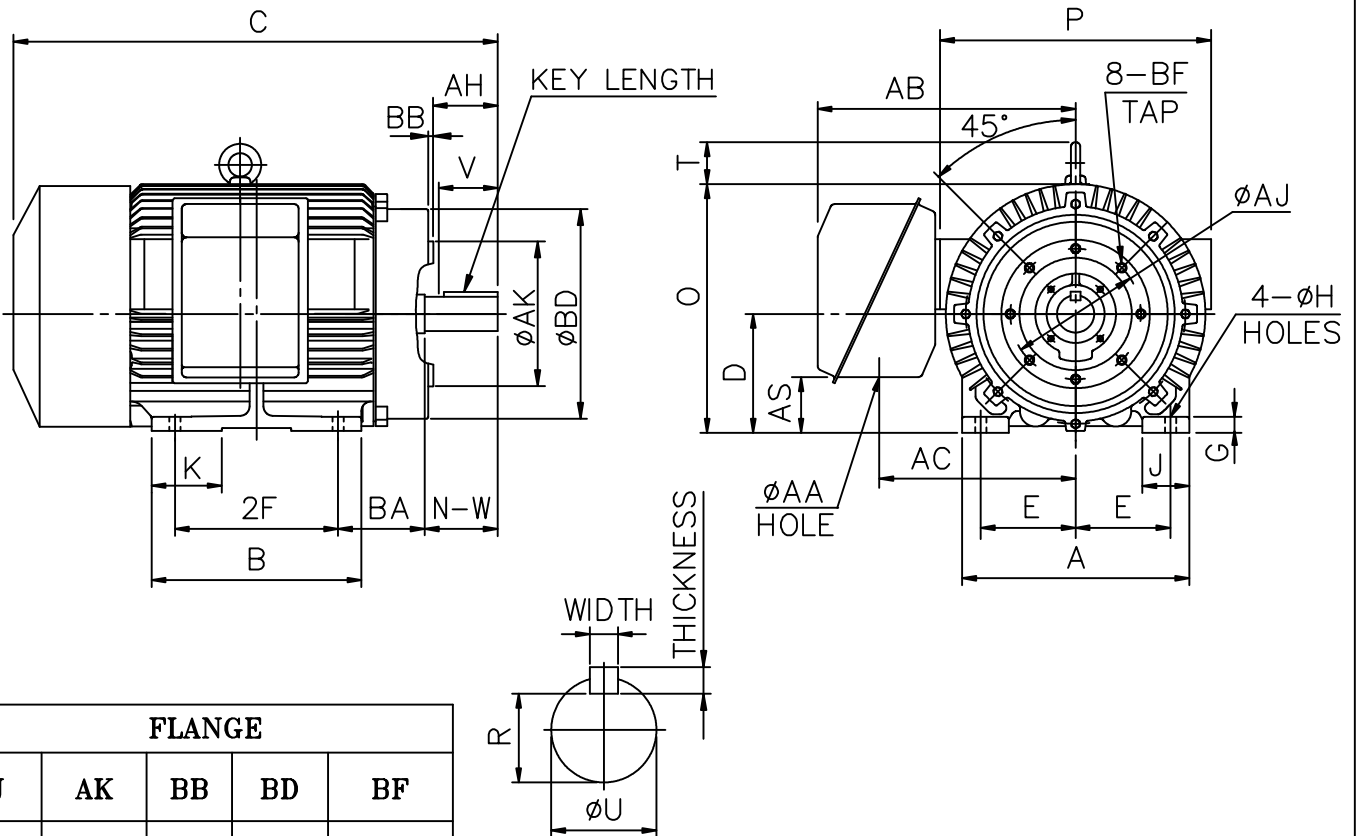

FLANGE				
AJ	AK	BB	BD	BF
14.00	16.00	0.25	16.93	5/8-11

A	B	C	D	E	2F	G	H	J	K	O+T	P	AA	AB	AH
22.05	17.32	46.10	11.00	9.00	14.50	1.18	0.83	4.33	4.72	26.54	25.83	4.65	22.24	8.25

AC	AS	BA	KEY			KEYSEAT R	SHAFT EXTENSION			BEARING NO.		APPROX WEIGHT
			WIDTH	THICKNESS	LENGTH		N-W	U	V	D.E	O.D.E	
17.32	6.31	7.50	0.875	0.875	6.91	2.880	8.50	3.375	8.25	6220	6315	1900 lb

- NOTE: 1. TOLERANCE OF SHAFT END DIAMETER U: +0.000, -0.001
 2. TOLERANCE OF SHAFT CENTER HEIGHT D: +0.000, -0.06
 3. DIMENSION R TOLERANCE: +0.000, -0.015
 4. DIMENSION AK TOLERANCE: +0.000, -0.005
 5. DIMENSION V IS LENGTH OF STRAIGHT PART OF SHAFT.
 6. F CLASS INSULATION.

初步圖面，僅供參考

CERTIFIED BY : _____ DATE : _____

DESIGNED	W. D. KUO	DWG. NO: AS-832463
CHECKED	L. J. LEE	3RD ANGLE PROJECTION
APPROVED	T. M. LIAO	DIMENSION IN inch

