

# OUTLINE 3-PHASE INDUCTION MOTOR

TOTALLY ENCLOSED FAN  
COOLED, SQUIRREL CAGE  
ROTOR

FILE NO:

CUSTOMER:

PO. NO:

ORDER NO:

OUTPUT	POLE	SYN. SPEED	VOLT.	FREQ	TIME RATING	MODEL	FRAME NO.
	2				CONT.	TEFC	364TSC

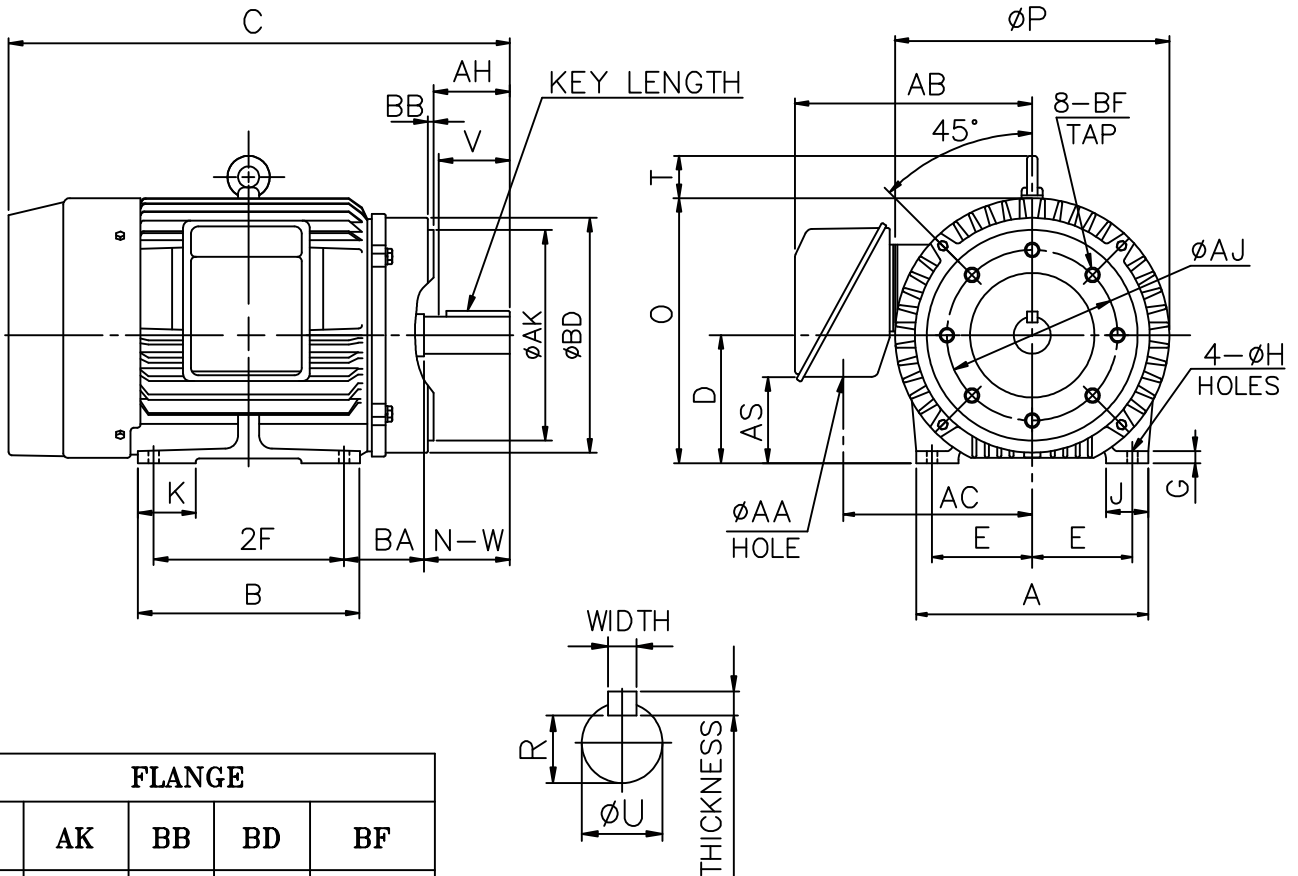

FLANGE				
AJ	AK	BB	BD	BF
11.00	12.50	0.25	14.00	5/8-11

A	B	C	D	E	2F	G	H	J	K	O+T	P	AA	AB	AH
16.40	14.40	30.41	9.00	7.00	11.25	0.93	0.66	3.15	4.73	21.30	19.29	3.58	17.32	3.50

AC	AS	BA	KEY			KEYSEAT	SHAFT EXTENSION			BEARING NO.		APPROX WEIGHT
			WIDTH	THICKNESS	LENGTH	R	N-W	U	V	D.E	O.D.E	
13.78	5.71	5.88	0.500	0.500	2.00	1.591	3.75	1.875	3.50	6312C3	6312C3	800 lb

- NOTE: 1. TOLERANCE OF SHAFT END DIAMETER U: +0.000, -0.001  
 2. TOLERANCE OF SHAFT CENTER HEIGHT D: +0.00, -0.06  
 3. DIMENSION R TOLERANCE: +0.000, -0.015  
 4. DIMENSION AK TOLERANCE: +0.000, -0.005  
 5. DIMENSION V IS LENGTH OF STRAIGHT PART OF SHAFT.  
 6. F CLASS INSULATION.

初步圖面，僅供參考

CERTIFIED BY : \_\_\_\_\_ DATE : \_\_\_\_\_

DESIGNED	W. D. KUO	DWG. NO: AS-832478
CHECKED	L. J. LEE	3RD ANGLE PROJECTION
APPROVED	T. M. LIAO	DIMENSION IN inch

