

OUTLINE 3-PHASE INDUCTION MOTOR

TOTALLY ENCLOSED FAN
COOLED, SQUIRREL CAGE
ROTOR

FILE NO:

CUSTOMER:

PO. NO:

ORDER NO:

OUTPUT	POLE	SYN. SPEED	VOLT.	FREQ	TIME RATING	MODEL	FRAME NO.
					CONT.	TEFC	324TC

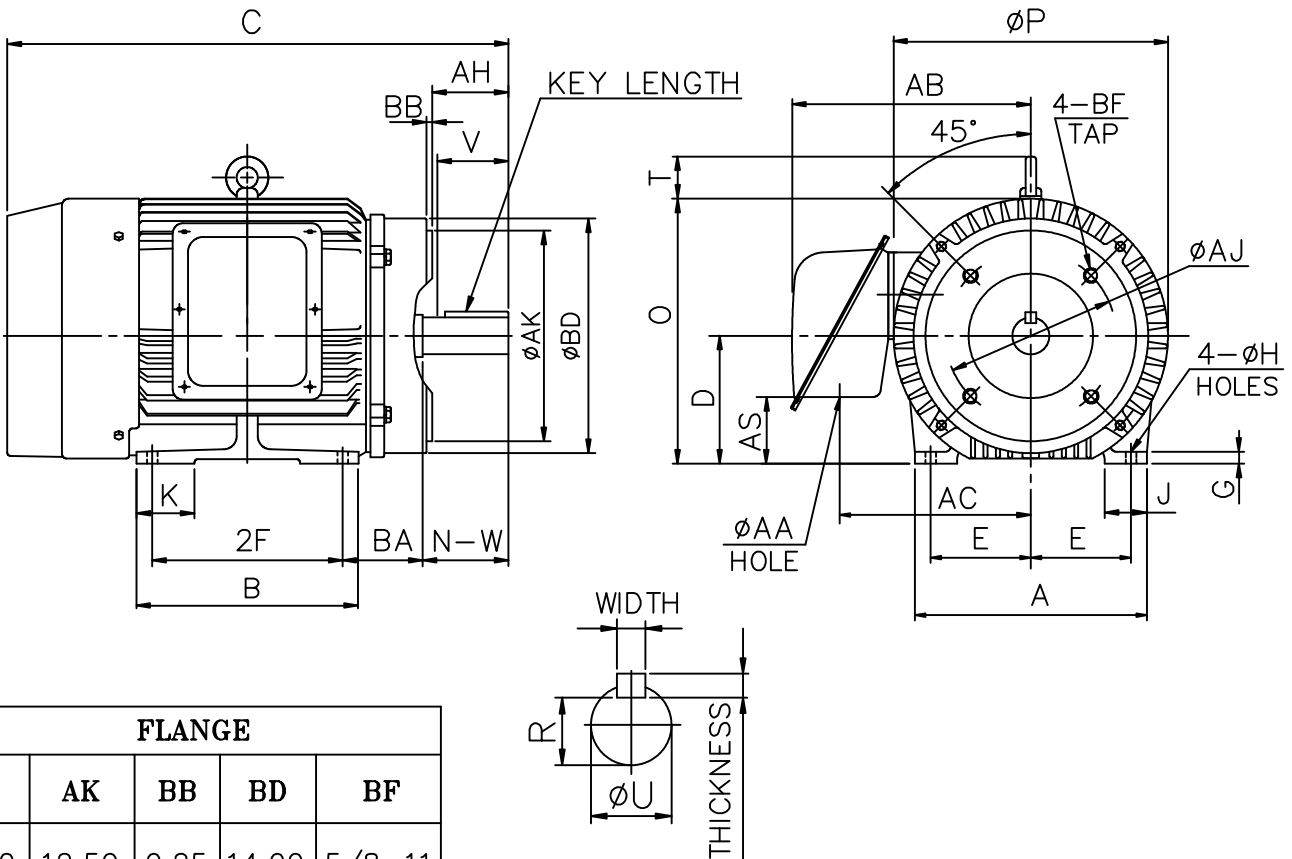

FLANGE				
AJ	AK	BB	BD	BF
11.00	12.50	0.25	14.00	5/8-11

A	B	C	D	E	2F	G	H	J	K	O+T	P	AA	AB	AH
14.88	12.68	29.82	8.00	6.25	10.50	0.91	0.66	3.15	3.15	19.13	17.79	2.48	14.40	5.0

AC	AS	BA	KEY			KEYSEAT	SHAFT EXTENSION			BEARING NO.		APPROX WEIGHT
			WIDE	THICKNESS	LENGTH	R	N-W	U	V	D.E	O.D.E	
11.73	5.44	5.25	0.500	0.500	3.875	1.845	5.25	2.125	5.00	6312	6212	590 lb

NOTE: 1. TOLERANCE OF SHAFT END DIAMETER U: 0.000, -0.001

2. TOLERANCE OF SHAFT CENTER HEIGHT D: 0.00, -0.06

3. DIMENSION R TOLERANCE: 0.000, -0.015

4. DIMENSION AK TOLERANCE: 0.000, -0.005

5. DIMENSION V IS LENGTH OF STRAIGHT PART OF SHAFT.

初步圖面，僅供參考

6. F CLASS INSULATION.

CERTIFIED BY : _____ DATE : _____

DESIGNED	W. D. KUO	DWG. NO: AS-832513
CHECKED	L. J. LEE	3RD ANGLE PROJECTION
APPROVED	T. M. LIAO	DIMENSION IN inch

