

OUTLINE 3-PHASE INDUCTION MOTOR

TOTALLY ENCLOSED FAN
COOLED, SQUIRREL CAGE
ROTOR

FILE NO:

CUSTOMER:

PO. NO:

ORDER NO:

OUTPUT	POLE	SYN. SPEED	VOLT.	FREQ	TIME RATING	MODEL	FRAME NO.
	2				CONT.	TEFC	284TSC

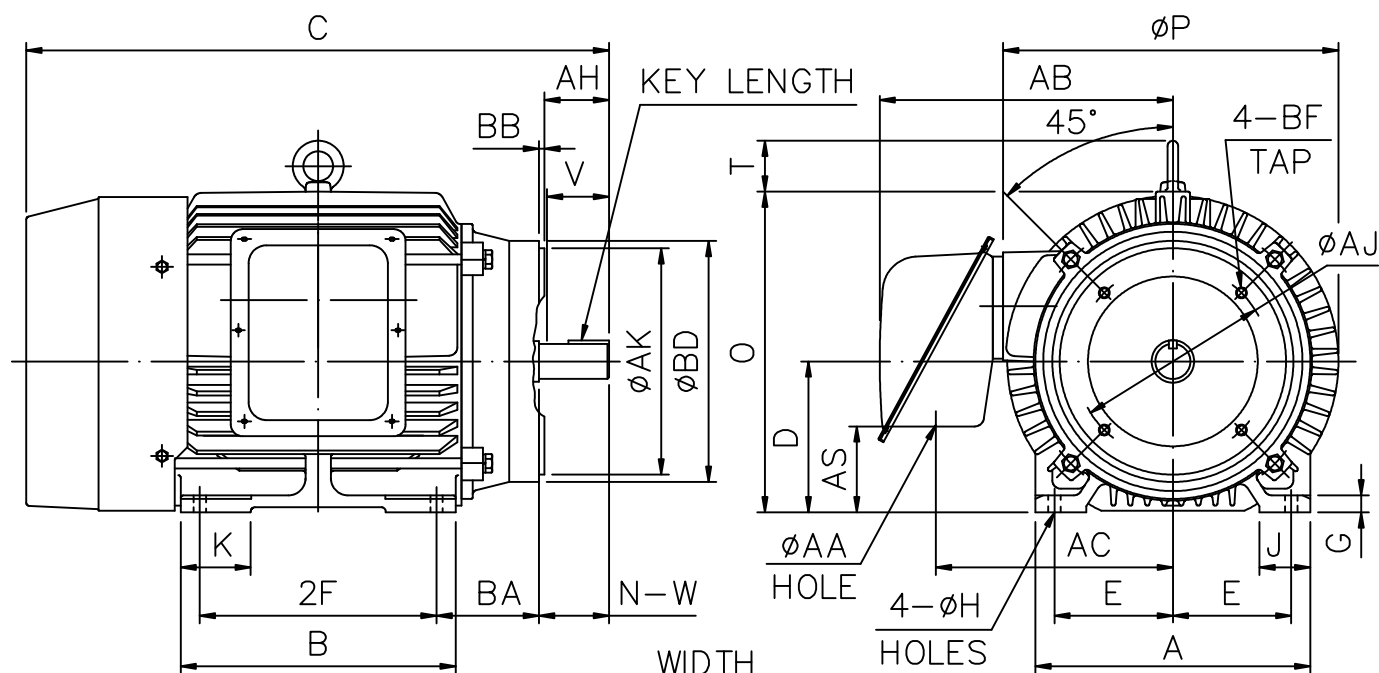

FLANGE

AJ	AK	BB	BD	BF
9.00	10.50	0.25	11.25	1/2-13

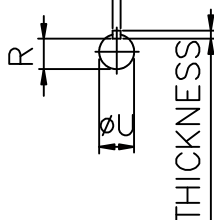

A	B	C	D	E	2F	G	H	J	K	O+T	P	AA	AB	AH
12.76	11.26	25.53	7.00	5.50	9.50	0.79	0.53	2.36	3.25	17.30	15.67	2.48	13.4	3.00

AC	AS	BA	KEY			KEYSEAT	SHAFT EXTENSION			BEARING NO.		APPROX WEIGHT
			WIDTH	THICKNESS	LENGTH	R	N-W	U	V	D.E	O.D.E	
11.0	4.05	4.75	0.375	0.375	1.91	1.416	3.25	1.625	3.20	6310ZZ	6210ZZ	403 lb

NOTE:1. TOLERANCE OF SHAFT END DIAMETER U: +0.000, -0.001

2. TOLERANCE OF SHAFT CENTER HEIGHT D: +0.000, -0.03

3. DIMENSION R TOLERANCE: +0.000, -0.015

4. DIMENSION AK TOLERANCE: +0.000, -0.003

5. DIMENSION V IS LENGTH OF STRAIGHT PART OF SHAFT. 初步圖面，僅供參考

6. F CLASS INSULATION.

CERTIFIED BY : _____ DATE : _____

DESIGNED W. D. KUO DWG. NO: AS-832567

CHECKED L. J. LEE 3RD ANGLE PROJECTION

APPROVED T. M. LIAO DIMENSION IN inch

