

OUTLINE 3-PHASE INDUCTION MOTOR

TOTALLY ENCLOSED FAN
COOLED, SQUIRREL CAGE
ROTOR

FILE NO:
CUSTOMER:
PO. NO:
ORDER NO:

OUTPUT	POLE	SYN. SPEED	VOLT.	FREQ	TIME RATING	MODEL	FRAME NO.
					CONT.	TEFC	184TC

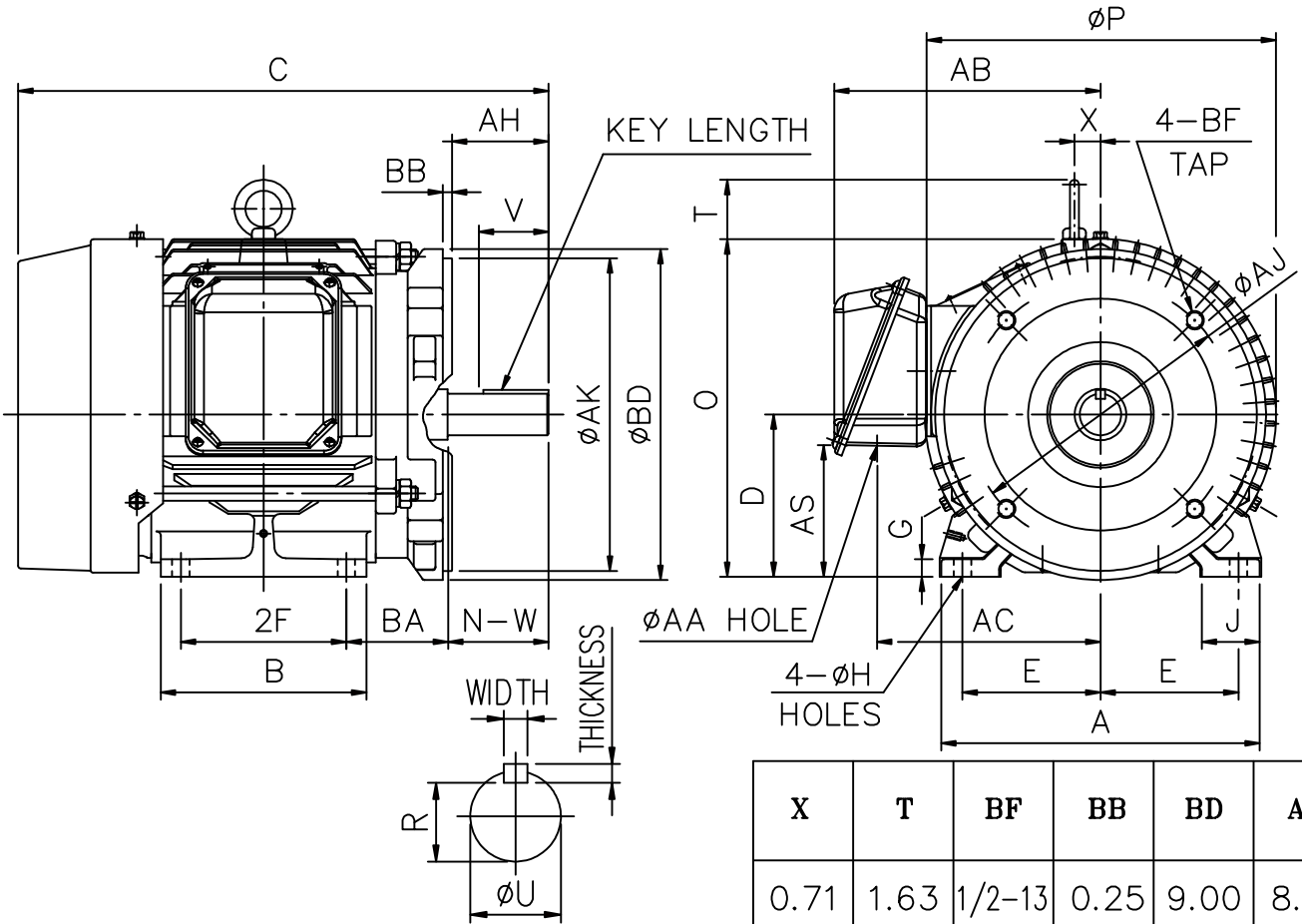

MOUNTING				A	B	C	D	G	J	O	AH	P	AJ
E	2F	H	BA										
3.75	5.50	0.41	2.75	8.66	6.61	15.42	4.50	0.56	1.57	9.27	2.62	9.55	7.250

AC	KEY			KEYSEAT	CONDUIT BOX			SHAFT EXTENSION			BEARING NO.		APR. WT.
	WIDTH	THICKNESS	LENGTH	R	AS	AA	AB	N-W	U	V	D.E	O.D.E	
5.91	0.250	0.250	1.750	0.986	3.63	1.10	7.09	2.75	1.125	2.70	6207ZZ	6206ZZ	120 lb

- NOTE: 1. TOLERANCE OF SHAFT END DIAMETER U: +0.000, -0.0005
 2. TOLERANCE OF SHAFT CENTER HEIGHT D: +0.000, -0.03
 3. DIMENSION R TOLERANCE: +0.000, -0.015
 4. DIMENSION AK TOLERANCE: +0.000, -0.003
 5. DIMENSION V IS LENGTH OF STRAIGHT PART OF SHAFT.
 6. F CLASS INSULATION.

初步圖面，僅供參考

CERTIFIED BY : _____ DATE : _____

DESIGNED W. D. KUO DWG. NO: AS-860501

CHECKED L. J. LEE 3RD ANGLE PROJECTION

APPROVED T. M. LIAO DIMENSIONS IN inch

